



Adding Intelligence to Media

XMP SPECIFICATION PART 3

STORAGE IN FILES

August 2016



Copyright © 2016 Adobe. All rights reserved.

Adobe XMP Specification Part 3: Storage in Files

NOTICE: All information contained herein is the property of Adobe Systems Incorporated. No part of this publication (whether in hardcopy or electronic form) may be reproduced or transmitted, in any form or by any means, electronic, mechanical, photocopying, recording, or otherwise, without the prior written consent of Adobe Systems Incorporated.

Adobe, the Adobe logo, Acrobat, Acrobat Distiller, Flash, FrameMaker, InDesign, Illustrator, Photoshop, PostScript, and the XMP logo are either registered trademarks or trademarks of Adobe Systems Incorporated in the United States and/or other countries.

MS-DOS, Windows, and Windows NT are either registered trademarks or trademarks of Microsoft Corporation in the United States and/or other countries. Apple, Macintosh, Mac OS and QuickTime are trademarks of Apple Computer, Inc., registered in the United States and other countries. UNIX is a trademark in the United States and other countries, licensed exclusively through X/Open Company, Ltd. All other trademarks are the property of their respective owners.

This publication and the information herein is furnished AS IS, is subject to change without notice, and should not be construed as a commitment by Adobe Systems Incorporated. Adobe Systems Incorporated assumes no responsibility or liability for any errors or inaccuracies, makes no warranty of any kind (express, implied, or statutory) with respect to this publication, and expressly disclaims any and all warranties of merchantability, fitness for particular purposes, and noninfringement of third party rights.

Contents

1	Embedding XMP metadata in application files	9
1.1	Image formats	9
1.1.1	DNG (Digital Negative)	9
1.1.2	GIF (Graphic Interchange Format)	11
1.1.3	JPEG	12
1.1.4	JPEG 2000	15
1.1.5	PNG (Portable Network Graphics)	16
1.1.6	TIFF (Tagged Image File Format)	17
1.1.7	SVG (Scalable Vector Graphics)	19
1.2	Dynamic media formats	20
1.2.1	ASF (WMA, WMV)	20
1.2.2	FLV (Flash® Video)	20
1.2.3	IFF/RIFF (AVI, WAV, AIFF)	22
1.2.4	MOV (QuickTime)	24
1.2.5	MP3	24
1.2.6	MPEG-2	25
1.2.7	MPEG-4 (generic and F4V)	25
1.2.8	SWF (Flash)	26
1.3	Video package formats	26
1.3.1	AVCHD	27
1.3.2	P2	27
1.3.3	Sony HDV (High Definition Video)	28
1.3.4	XDCAM	29
1.4	Adobe application formats	32
1.4.1	AI (Adobe Illustrator®)	32
1.4.2	INDD, INDT (Adobe InDesign®)	32
1.4.3	PSD (Adobe Photoshop)	37
1.5	Markup formats	38
1.5.1	HTML	38
1.5.2	XML	39
1.6	Document formats	39
1.6.1	PDF	39
1.6.2	PS, EPS (PostScript® and Encapsulated PostScript)	40
1.6.3	UCF (Universal Container Format)	46
2	Handling native metadata	49
2.1	Reconciling metadata in different formats	49
2.1.1	Text encodings in import and export	49
2.1.2	Native metadata export and import	50
2.1.3	Use of native metadata digests	51
2.2	Native metadata in PDF files	51
2.2.1	User-defined keys	51
2.2.2	Resolving metadata conflicts	52
2.3	Native metadata in dynamic media formats	52
2.3.1	Native metadata in ASF (WMA, WMV) formats	52
2.3.2	Native metadata in IFF/RIFF (AVI, WAV, AIFF) formats	53
2.3.3	Native metadata in MP3	57
2.3.4	Native metadata in MPEG-4	58
2.4	Native metadata in digital photography formats	59
2.4.1	Reconciliation issues	60
2.4.2	Encoding of text in metadata	61
3	Digital photography native metadata	63

XMP name	19
3.1 Metadata storage in native formats	63
3.1.1 TIFF metadata	63
3.1.2 Exif metadata	63
3.1.3 Photoshop image resources	64
3.1.4 IPTC (IIM) metadata	65
3.2 Reconciling metadata properties	66
3.2.1 Photoshop image resources for metadata	66
3.2.2 IPTC DataSets for metadata	67
3.2.3 TIFF and Exif tags for metadata	69
3.3 Metadata storage	72
3.3.1 Storage by metadata form	72
3.3.2 Metadata storage in JPEG files	73
3.3.3 Metadata storage in Photoshop files	74
3.3.4 Metadata storage in TIFF files	74
3.3.5 Metadata storage in Mac OS file resources	76
Table 52 — Mac OS Photoshop resources from older versions	76

Preface

This document set provides a complete specification for the [Extensible Metadata Platform \(XMP\)](#), which provides a standard format for the creation, processing, and interchange of metadata, for a wide variety of applications.

The specification has three parts:

- *Part 1, Data Model, Serialization, and Core Properties*, covers the basic metadata representation model that is the foundation of the XMP standard format. The data model prescribes how XMP metadata can be organized; it is independent of file format or specific usage. The serialization model prescribes how the data model is represented in XML, specifically RDF/XML. Core properties are those XMP properties that have general applicability across a broad range of resources; these include general-purpose namespaces such as Dublin Core. This document also provides details needed to implement a metadata manipulation system such as the XMP Toolkit (which is available from Adobe®).
- *Part 2, Additional Properties*, provides detailed property lists and descriptions for standard XMP metadata namespaces beyond the core properties; these include special-purpose namespaces for Adobe applications such as Adobe Photoshop®. It also provides information on extending existing namespaces and creating new namespaces.
- *Part 3, Storage in Files*, provides information about how serialized XMP metadata is packaged into XMP packets and embedded in different file formats. It includes information about how XMP relates to and incorporates other metadata formats, and how to reconcile values that are represented in multiple metadata formats.

About this document

This document, *Adobe XMP Specification Part 3: Storage in Files*, describes how XMP metadata is embedded within various file formats. This includes information about the reconciliation of XMP metadata with other forms of metadata, referred to as *native* (or sometimes *legacy*) metadata.

The intended audience of this document is developers writing file I/O code, users who need to understand the relationship between XMP and native metadata, or others requiring detailed knowledge of file content.

How this document is organized

This document has the following sections:

- “[Introduction](#)” provides an overview of the issues and problems associated with storing metadata in or with different file formats. It includes an introduction to the subject of native metadata formats, and a discussion of external metadata storage.
- [1, “Embedding XMP metadata in application files”](#), provides basic information about how XMP packets are embedded in various file formats.
- [2, “Handling native metadata”](#), explains general policies of how to reconcile metadata values among XMP and native metadata formats. It provides details of native metadata for simpler cases, and introduces the complexities of native metadata for the digital-photography formats (JPEG, TIFF, and PSD).
- [3, “Digital photography native metadata”](#), provides details of metadata formats used in the digital-photography formats (TIFF/Exif, IPTC, and PSIR), and specifics of how properties in those formats map to XMP properties.

Document history

This release of this document (December 2014) has changed in these ways since the previous release (May 2013):

- Included an additional resource (iXML specifications) in [Where to go for more information](#)
- Added a note regarding Exif APP1 or PSIR APP13 markers at the end of the [JPEG](#) section
- Link correct for reconciliation with XMP detail in [WAV](#) section
- Included a new compatible brand 'avc1' in [MPEG-4 \(generic and F4V\)](#) section

- Added XML mapping information in Table 25 —, “Mapping of iXML chunk properties to XMP”
- Included information regarding Photoshop splitting PSIR blocks 3.2.2, “IPTC DataSets for metadata”

Conventions used in this document

The following type styles are used for specific types of text:

Table 1 — Conventions for type styles

Typeface Style	Used for
Monospaced bold	XMP property names. For example, xmp:CreateDate
Monospaced Regular	XML code and other literal values, such as value types and names in other languages or formats

Where to go for more information

See these sites for external specifications mentioned in this document:

Table 2 — Sources for additional information

XMP Specification	http://www.adobe.com/devnet/xmp/
Photoshop SDK	http://www.adobe.com/devnet/photoshop/
TIFF Specification	http://partners.adobe.com/public/developer/tiff/index.html
JPEG Specification	http://www.w3.org/Graphics/JPEG/itu-t81.pdf
JFIF Specification	http://www.w3.org/Graphics/JPEG/jfif3.pdf
Exif Specification	http://www.cipa.jp/std/documents/e/DC-008-2012_E.pdf
IPTC Specification	http://www.iptc.org/IPTC4XMP/
Unicode	http://www.unicode.org/
Metadata Working Group (MWG)	http://www.metadataworkinggroup.com/
iXML Specification	http://www.ixml.info/

Introduction

This document discusses how serialized XMP metadata is packaged and stored with the files it describes. It includes information about how XMP relates to and incorporates other metadata formats, and how to reconcile values that are represented in multiple metadata formats.

This chapter provides a basic overview of the concepts that are important to XMP storage and retrieval:

- Generally, XMP metadata is embedded in the file which the metadata describes; see [“Embedding metadata in files”](#). The details of how it is embedded vary according to the file format, and are discussed in later chapters.
- It is occasionally appropriate to store metadata separately from the file it describes; this is discussed briefly in [“External storage of metadata”](#).
- Any application that uses or modifies XMP metadata must be aware of native metadata formats, in order to detect them, preserve them, and reconcile any changes to values among all formats; see [“Native metadata”](#).

Embedding metadata in files

XMP metadata is serialized into XML, specifically RFD, for storage in files. The serialized data is known as an *XMP packet*. The structure of the XMP packet is discussed in *“XMP Specification Part 1, Data Model, Serialization, and Core Properties.”*

The XMP packet is completely self-contained and independent of any particular file format. Most file formats predate XMP, and do not have built-in specifications for how to include it. However, XMP can be placed into a file of any format that has a well-defined extension mechanism; that is, a way for developers to customize files for new uses.

File format specifications offer extension mechanisms as a portion of format-specific data that surrounds a chunk of user-defined custom data. In the case of XMP, the XMP packet is the custom data. The surrounding data, as defined by the format specification, identifies the extension’s boundaries and type.

The parameters for embedding custom data vary with different file formats. [1, “Embedding XMP metadata in application files”](#), provides embedding details for a variety of file formats.

External storage of metadata

It is recommended that XMP metadata be embedded in the file that the metadata describes. There are cases where this is not appropriate or possible, such as database storage models, extremes of file size, or format and access issues. Small content intended to be frequently transmitted over the Internet might not tolerate the overhead of embedded metadata. Archival systems for video and audio might not have any means to represent the metadata. Some high-end digital cameras have a proprietary, nonextensible file format for “raw” image data and typically store Exif metadata as a separate file.

If metadata is stored separately from content, there is a risk that the metadata can be lost. The question arises of how to associate the metadata with the file containing the content. Applications should:

- Write the external file as a complete, well-formed XML document, including the leading XML declaration.
- Use the file extension `.xmp`. For Mac OS, optionally set the file’s type to `'TEXT'`.
- If a MIME type is needed, use `application/rdf+xml`.
- Write external metadata as though it were embedded and then had the XMP packets extracted and catenated by a postprocessor.
- If possible, place the values of the `xmpMM:DocumentID`, `xmpMM:InstanceID`, or other appropriate properties within the file the XMP describes, so that format-aware applications can make sure they have the right metadata.

For applications that need to find external XMP files, look in the same directory for a file with the same name as the main document but with an `.xmp` extension. (This is called a *sidecar* XMP file.)

Native metadata

Files in many formats can contain metadata in other, previously-defined or *native* formats. Still image formats, for example, frequently contain IPTC and TIFF/Exif metadata. When a file is imported, it can contain metadata in one or more of these native formats. Similarly, when a file is exported, it may be read by a device or application that is expecting metadata in native formats, and may or may not support the XMP format. The information represented overlaps to a great degree, and values that are present in any format should be reflected in all others.

An application that supports XMP must read metadata values from the native formats, and represent it correctly in the XMP metadata. When modifying XMP metadata, an application is responsible for correctly reflecting changes in any other metadata formats that are present. A file that has been manipulated by an application that supports XMP might later be opened in an application that relies on another metadata format, and any changes that have been made to the XMP metadata must be properly represented.

Users of the XMP Toolkit, which handles most native metadata reconciliation, should still be aware of the issues in order to recognize potential problems to look for when testing with legacy application or file versions.

- For general issues and policy on metadata reconciliation, see [2, “Handling native metadata”](#).
- For an in-depth discussion of complex issues pertaining to still image formats (JPEG, TIFF, and PSD), see [3, “Digital photography native metadata”](#).

1 Embedding XMP metadata in application files

This chapter describes how XMP metadata in XMP packets is embedded in a variety of file formats. Document interchange is best achieved by applications that understand how XMP is embedded. These descriptions assume that the reader has a working knowledge of the referenced file formats.

The formats are listed in [Table 3](#) alphabetically within general categories:

Table 3 — File formats using XMP

1.1, "Image formats"	DNG (Digital Negative) GIF (Graphic Interchange Format) JPEG JPEG 2000 PNG (Portable Network Graphics) SVG (Scalable Vector Graphics) TIFF (Tagged Image File Format)
1.2, "Dynamic media formats"	ASF (WMA, WMV) FLV (Flash® Video) IFF/RIFF (AVI, WAV, AIFF) MOV (QuickTime) MP3 MPEG-2 MPEG-4 (generic and F4V) SWF (Flash)
1.3, "Video package formats"	AVCHD P2 Sony HDV (High Definition Video) XDCAM
1.4, "Adobe application formats"	AI (Adobe Illustrator®) INDD, INDT (Adobe InDesign®) PSD (Adobe Photoshop)
1.5, "Markup formats"	HTML XML
1.6, "Document formats"	PDF PS, EPS (PostScript® and Encapsulated PostScript) UCF (Universal Container Format)

1.1 Image formats

- 1.1.1, "DNG (Digital Negative)"
- 1.1.2, "GIF (Graphic Interchange Format)"
- 1.1.3, "JPEG"
- 1.1.4, "JPEG 2000"
- 1.1.5, "PNG (Portable Network Graphics)"
- 1.1.6, "TIFF (Tagged Image File Format)"

1.1.1 DNG (Digital Negative)

DNG is a publicly documented, standardized format created by Adobe for storage of raw image data as captured by digital cameras. It was created as an alternative to the more than 400 wildly varying formats all called "camera raw;" see [1.1.1.1, "Camera raw formats"](#).

DNG files can embed XMP metadata; they are, in fact, well-behaved TIFF. They can be processed by the Adobe DNG SDK, by the Adobe Camera Raw (ACR) SDK, or by the TIFF handler in the XMP Toolkit. The primary difference between the Adobe DNG/ACR handlers and the XMP Toolkit TIFF handler is that the TIFF handler does not interpret the Exif MakerNote tag.

Metadata can be embedded in DNG in the following ways:

- Using TIFF or Exif metadata tags
- Using the IPTC metadata tag (33723)
- Using the XMP metadata tag (700)

Note that TIFF and Exif use nearly the same metadata tag set, but TIFF stores the tags in IFD 0, while Exif store the tags in a separate IFD. Either location is allowed by DNG, but the Exif location is preferred. See 3.2.3, “TIFF and Exif tags for metadata”.

For further information on this file format, see <http://www.adobe.com/products/dng/>

1.1.1.1 Camera raw formats

Many raw formats look like TIFF, but do not behave as expected in various ways. Do not attempt to process camera raw files with generic TIFF software. Similarly, you should not pass a raw-format file directly to XMP Toolkit file handlers (XMPFiles), but should use the Adobe Camera Raw (ACR) SDK instead.

When writing your own metadata handler for camera raw files, it can be difficult to distinguish a possible camera raw file from a generic TIFF file. A pragmatic partial solution is to filter by file extension. Known camera raw extensions include :

Table 4 — Camera raw file extensions

File extension	Company	File extension	Company
DNG	Adobe	TIF	Canon, Kodak
CRW	Canon	CR2	Canon
ERF	Epson		
X3F	Foveon	RAF	Fujifilm
3FR	Hasselblad	FFF	Hasselblad
KDC	Kodak	DCR	Kodak
MOS	Leaf	RWL	Leica
MFW	Mamiya (sample files)	MEF	Mamiya (sample camera)
MRW	Minolta	ORF	Olympus
NEF	Nikon	NRW	Nikon
RW2	Panasonic	RAW	Panasonic, Contax
PEF	Pentax	IIQ	Phase One
SRW	Samsung	ARW	Sony
SRF	Sony	SR2	Sony

1.1.2 GIF (Graphic Interchange Format)

In a GIF 89a file, an XMP packet is in an Application Extension (see [Figure 1](#)). Its Application Identifier is 'XMP Data' and the Application Authenticator is 'XMP'. The Application Data consists of the XMP packet, which must be encoded as UTF-8, followed by a 258-byte “magic” trailer, whose values are 0x01, 0xFF, 0xFE, 0xFD ...0x03, 0x02, 0x01, 0x00, 0x00. The final byte is the Block Terminator.

NOTE The "Application Extension" mechanism used for XMP was added in the 89a revision of GIF; the GIF 87a standard does not support it. XMP should not be placed into GIF 87a files.

The XMP must be UTF-8-encoded, for the following reasons. GIF actually treats the Application Data as a series of GIF data sub-blocks. The first byte of each sub-block is the length of the sub-block’s content, not counting the first byte itself. To consume the Application Data, a length byte is read. If it is non-zero, that many bytes of data are read, followed by the next length byte. The series ends when a zero-length byte is encountered.

When XMP is encoded as UTF-8, there are no zero bytes in the XMP packet. Therefore, software that is unaware of XMP views packet data bytes as sub-block lengths, and follows them through the packet accordingly, eventually arriving somewhere in the magic trailer. The trailer is arranged so whichever byte is encountered there will cause a skip to the Block Terminator at the end.

[Figure 1](#) shows how XMP is embedded in the GIF file format:

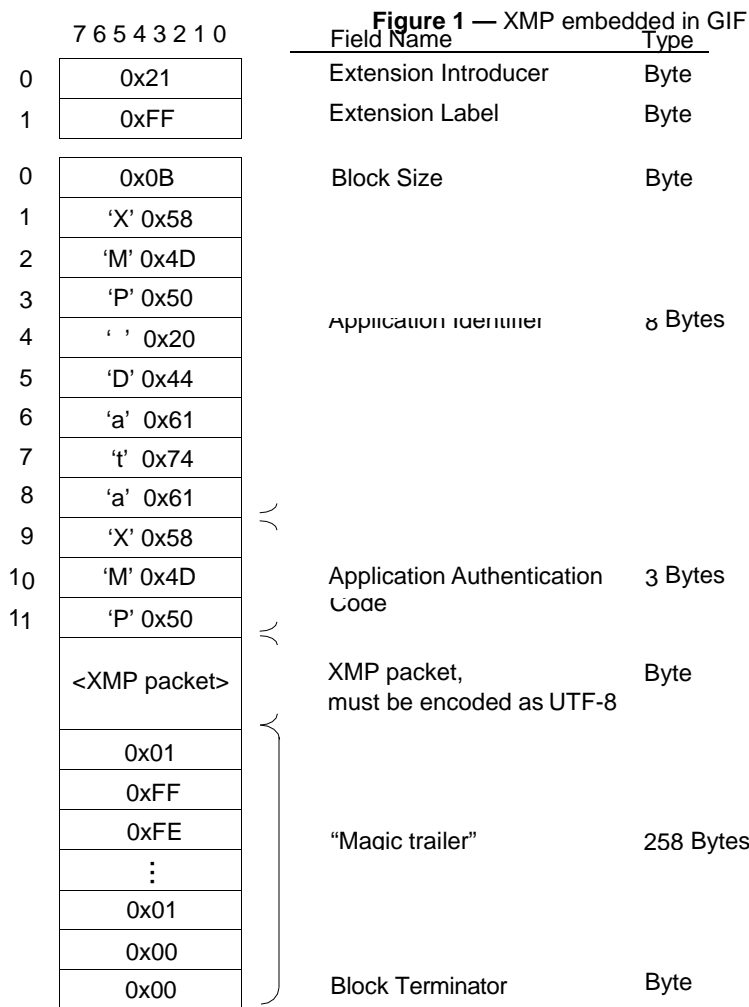

For reference information, see the GIF 89a specification at:

- <http://www.w3.org/Graphics/GIF/spec-gif89a.txt>

1.1.3 JPEG

The JPEG (Joint Photographic Experts Group) specification concerns itself almost entirely with the image compression algorithm, and has very little to say about the remainder of the file format. It specifies a sequence of 2-byte markers, interspersed among data. Each marker defines the interpretation of data that follows it. According to the JPEG standard, any number of marker segments may appear in any order; the Exif standard built upon JPEG defines some ordering restrictions.

The first byte of each marker is 0xFF, the second byte is a type identifier the range 0x01..0xFE; the marker is followed by data which extends to the next marker. The pairs 0xFF00 and 0xFFFF are not markers. A marker can be preceded by any number of 0xFF fill bytes. Restart markers can appear within the compressed image stream: any 0xFF byte in the compressed image has a 0x00 byte inserted after it so that it does not appear to be a marker.

The marker types FFE0-FFE7 are generally used for application data, named APP*n*. By convention, an APP*n* marker begins with a string identifying the usage, called a *namespace* or *signature string*. An APP1 marker identifies Exif and TIFF metadata; an APP13 marker designates a Photoshop Image Resource (PSIR) that contains IPTC metadata; another APP1 marker designates the location of the XMP packet.

Figure 2 shows APP markers within JPEG.

Figure 2 — Layout of JPEG with APP markers

Markers
<i>(other markers)</i>
APP1: Exif/TIFF
APP1: XMP
APP13: PSIR/
<i>(other markers)</i>
SOF marker
Image data

The JFIF standard has been largely abandoned; most importantly, all modern digital cameras follow Exif. Both JFIF and Exif specify a particular APP*n* marker segment as immediately following the SOI marker. Neither of the JFIF and Exif specifications references the other, so there is no declared standard for mixing them. Readers should be prepared to encounter files that contain an Exif APP1 marker segment following the JFIF and JFXX APP0 marker segments.

The XMP APP1 and PSIR/IPTC APP13 markers must be placed before the first SOF marker. For maximum compatibility, readers should tolerate finding them between the first SOF marker and first SOS marker. (Earlier versions of the *XMP Specification* were ambiguous about the placement rules.)

After the type, the marker contains a length value and the identifying namespace string. The length value is 2 (the length field itself) plus the length of the namespace field, plus the length of the data in bytes. Metadata markers share the convention of having NULL-terminated namespace strings:

Table 5 — Content and usage of APP markers

Marker	Signature, including NULLs	Usage
APP1	"Exif\0\0" (2 NULLs)	TIFF and Exif metadata
APP1	"http://ns.adobe.com/xap/1.0\0"	XMP
APP13	"Photoshop 3.0\0"	Photoshop image resources, including IPTC metadata, but not including XMP or Exif metadata

Table 6 shows the entry format for the XMP section:

Table 6 — Entry format for XMP section in JPEG

Byte offset, length	Field value	Field name	Comments
0, 2 bytes	0xFFE1	APP1	APP1 marker identifies metadata section.
2, 2 bytes	2 + 29 + length of XMP packet	Lp	Size in bytes of this count plus the following two portions.
4, 29 bytes	Null-terminated ASCII string without quotation marks	namespace	XMP namespace URI, used as unique ID: <code>http://ns.adobe.com/xap/1.0/</code>
33, < 65503	XMP packet		Must be encoded as UTF-8.

The JPEG standard does not prescribe ordering among APP n segments, but some related standards do. For example, Exif requires that Exif APP1 segment be immediately after the SOI. Also, some applications improperly assume that the segments are in a particular order. For compatibility, it is best to put the Exif APP1 first, the XMP APP1 next, the PSIR APP13 next, followed by all other marker segments.

NOTE If the size of the Exif APP1 marker or the PSIR APP13 marker exceeds 64KB, the marker is split into multiple blocks of 64KB size each.

JPEG is inherently a sequential file structure; however, nothing prevents the content of an APP n marker segment from having its own internal formatting. Exif, for example, embeds the linked TIFF data structure as the content of an APP1 marker segment.

1.1.3.1 Extended XMP in JPEG

Following the normal rules for JPEG sections, the header plus the following data can be at most 65535 bytes long. If the XMP packet is not split across multiple APP1 sections, the size of the XMP packet can be at most 65502 bytes. It is unusual for XMP to exceed this size; typically, it is around 2 KB.

If the serialized XMP packet becomes larger than the 64 KB limit, you can divide it into a main portion (*StandardXMP*) and an extended portion (*ExtendedXMP*), and store it in multiple JPEG marker segment. A reader must check for the existence of *ExtendedXMP*, and if it is present, integrate the data with the main XMP. Each portion (standard and extended) is a fully formed XMP metadata tree, although only the standard portion contains a complete packet wrapper. If the data is more than twice the 64 KB limit, the extended portion can also be split and stored in multiple marker segments; in this case, the split portions are not fully formed metadata trees.

When ExtendedXMP is required, the metadata must be split according to some algorithm that assigns more important data to the main portion, and less important data to the extended portions or portions. The definition of importance is up to the application; see 1.1.3.2, “Partitioning XMP”.

The main portion of the metadata tree must be serialized and written as the standard XMP packet, in the APP1 marker segment described above, called StandardXMP. The extended portion must be serialized without a packet wrapper, and written as a series of APP1 marker segments, collectively called the ExtendedXMP.

When written into the JPEG file, the serialized text for the ExtendedXMP can be further split as necessary into a series of roughly 65400 byte chunks. This number is not fixed; readers must tolerate other sizes. The upper limit on the ExtendedXMP chunk size is 65458 (65535 less the additional description bytes, 2+35+32+4+4). This second 64 KB split is a simple separation of the XML text into data chunks, without regard to XML tokens or even UTF-8 characters.

Each chunk is written into the JPEG file within a separate APP1 marker segment. Each ExtendedXMP marker segment contains:

- A null-terminated signature string of "http://ns.adobe.com/xmp/extension/".
- A 128-bit GUID stored as a 32-byte ASCII hex string, capital A-F, no null termination. The GUID is a 128-bit MD5 digest of the full ExtendedXMP serialization.
- The full length of the ExtendedXMP serialization as a 32-bit unsigned integer
- The offset of this portion as a 32-bit unsigned integer.
- The portion of the ExtendedXMP

The GUID is also stored in the StandardXMP as the value of the **xmpNote:HasExtendedXMP** property. This allows detection of mismatched or modified ExtendedXMP. A reader must incorporate only ExtendedXMP blocks whose GUID matches the value of **xmpNote:HasExtendedXMP**. The URI for the **xmpNote:** namespace is "http://ns.adobe.com/xmp/note/".

When partitioning the XMP and determining the remaining size of the StandardXMP, be sure to first add the **xmpNote:HasExtendedXMP** property to the StandardXMP with an initial 32-byte dummy value. This ensures accurate values for the size of the StandardXMP serialization, which must contain the **xmpNote:HasExtendedXMP** property.

A JPEG writer should write the ExtendedXMP marker segments in order, immediately following the StandardXMP. However, the JPEG standard does not require preservation of marker segment order. A robust JPEG reader should tolerate the marker segments in any order.

The offset field of the marker segment is the offset of this chunk of the ExtendedXMP serialization within the full ExtendedXMP serialization. The first chunk has offset 0, the second chunk has an offset equal to the first chunk's size, and so on. The offsets allow proper reconstruction of the ExtendedXMP serialization even if the APP1 marker segments are reordered.

A JPEG reader must recompose the StandardXMP and ExtendedXMP into a single data model tree containing all of the XMP for the JPEG file, and remove the **xmpNote:HasExtendedXMP** property.

1.1.3.2 Partitioning XMP

The *XMP Specification* does not mandate any particular procedure for separating XMP into standard and extended portions. However, it is a good idea for certain things to be in the first packet, so that older handlers and implementations that recognize only the first packet will still work. Adobe products follow these recommendations and guidelines to ensure that the most important data fields go into the first packet:

- To avoid partitioning when possible, the StandardXMP serialization should be as small as possible, making full use of RDF shorthand and eliminating all formatting whitespace. If the StandardXMP is too large, try to reduce or eliminate the packet-padding whitespace.

- If the StandardXMP is still too large, delete any existing **xmp:Thumbnails** property. (Applications should avoid use of the **xmp:Thumbnails** property in JPEG files. The XMP form of the thumbnail is relatively large, and the Exif form of JPEG has a standard native thumbnail that is already produced by most or all digital cameras.)
- If the StandardXMP packet is still too large, move these items to the extension portion, in order, until the remaining StandardXMP is small enough:
 - All properties in the Camera Raw namespace.
 - The **photoshop:History** property.
- Other top-level properties in order of estimated serialized size, largest first.

For reference information, see:

- JPEG File Interchange Format (JFIF) Version 1.02.
- The JPEG specification on the W3C JPEG website: <http://www.w3.org/Graphics/JPEG/itu-t81.pdf>
- ISO/IEC 10918-1 Information technology — Digital Compression and Coding of continuous-tone still images: requirements and guidelines.
- ISO/IEC 10918-4 Information technology — Digital compression and coding of continuous-tone still images: Registration of JPEG profiles, SPIFF profiles, SPIFF tags, SPIFF color spaces, APP_n markers, SPIFF compression types and Registration Authorities (REGAUT). This specifies the format of APP_n markers and the file interchange format.

NOTE TIFF, JPEG, and PSD share complex issues of how native metadata formats are stored; see 2.4, “Native metadata in digital photography formats”.

1.1.4 JPEG 2000

JPEG 2000 uses the ISO Base Media File Format. This is the same basic format as MPEG-4, although some internal details differ. The JPEG 2000 flavor of the file format is ISO/IEC 15444-12, the MPEG-4 flavor is ISO/IEC 14496-12. The ISO Base Media File Format is a “chunky” file format, similar to QuickTime or RIFF (AVI and WAV). In this case the chunks are called *boxes*.

Each box consists of a header followed by data. The structure of the header is shown in Table 7:

Table 7 — Structure of JPEG box header

Offset, length	Description
0, 4 bytes	32-bit, unsigned, big-endian value, the size of the box. The size includes both the header and data portions of the box. If the size does not fit into 32 bits, this value is 1, and the size value is in the extended size field. Value is 0 if the box extends to the end of the file; in this case, no extended size value is present.
4, 4 bytes	32-bit, unsigned, big-endian value, the type code. Typically defined as 4 ASCII characters, shown in file order. The standard extension mechanism is the UUID box. The data portion of a UUID box must begin with a 16-byte unique ID (“uuid”).
8, 8 bytes	64-bit, unsigned, big-endian value, the extended size (if needed).

XMP packets are stored in a UUID box, as shown in [Table 8](#):

Table 8 — Structure of UUID box

Field value	Field name	Length (bytes)	Comments
Entire length in bytes (including the four used for this field)	Length	4	Big-endian unsigned integer
0x75756964 ('uuid')	Type	4	Big-endian unsigned integer
BE 7A CF CB 97 A9 42 E8 9C 71 99 94 91 E3 AF AC	UUID	16	16-byte binary UUID as defined by ISO/IEC 11578:1996
< XMP packet >	DATA		Must be encoded as UTF-8

For reference information, see the JPEG 2000 standard: <http://www.jpeg.org/JPEG2000.html>

1.1.5 PNG (Portable Network Graphics)

An XMP packet is embedded in a PNG graphic file by adding a chunk of type iTXt. This chunk is semantically equivalent to the tEXt and zTXt chunks, but the textual data is in the UTF-8 encoding of the Unicode character set, instead of Latin-1.

The Chunk Data portion is the XMP packet. The packet must be marked as read-only. XMP software that is not aware of the file format must not be allowed to change the content of the XMP packet because of the CRC checksum following the chunk data.

There should be no more than one chunk containing XMP in each PNG file. Encoders are encouraged to place the chunk at the beginning of the file, but this is not required.

The PNG data format is shown in [Table 9](#).

Table 9 — PNG data format

Field	Length	Comments
Length	4	An unsigned integer representing the number of bytes in the chunk's data field (does not include the chunk type code or the CRC).
Chunk Type	4	"iTXt"
Chunk Data		Standard iTXt chunk header plus the XMP packet
Keyword	17	"XML:com.adobe.xmp"
Null separator	1	value = 0x00
Compression flag	1	value = 0x00, specifies uncompressed data
Compression method	1	value = 0x00
Language tag	0	Not used for XMP metadata
Null separator	1	value = 0x00
Translated keyword	0	Not used for XMP metadata

Table 9 — PNG data format (Continued)

Field	Length	Comments
Null separator	1	value = 0x00
Text	length of packet	The XMP packet, must be encoded as UTF-8
CRC	4	The Cyclic Redundancy Check, calculated on the preceding bytes in the chunk, including the chunk type code and chunk data fields, but not including the length field.

For reference information, see: <http://www.w3.org/TR/REC-png.html>

1.1.6 TIFF (Tagged Image File Format)

Tagged Image File Format (abbreviated TIFF or TIF) is a file format for storing images, including photographs and line art, and also a metadata format. A number of other formats, including DNG for camera raw data and Exif for metadata, are also well-behaved TIFF. Many camera raw formats, however, look like TIFF but are not well-behaved and cannot be processed by a TIFF handler.

The overall structure of a TIFF file is relatively simple: an 8-byte header and a chain of Image File Directories (IFDs). Table 10 shows the content of the file header:

Table 10 — TIFF file header

Offset, length	Description
0, 2 bytes	Byte order, "II" (0x4949) for little-endian, "MM" (0x4D4D) for big-endian.
2, 2 bytes	Identifies file as TIFF with the number 42 in the given byte order: 0x2A00 if little-endian, 0x002A if big-endian.
4, 4bytes	Offset of the first (0th) IFD. Each IFD begins with a 2-byte count of directory entries, followed by a sequence of 12-byte directory entries, followed by a 4-byte offset of the next IFD. The last IFD must have zero as the offset of the next IFD. The IFDs can be anywhere in the file (after the 8-byte header), in any order. Each IFD must be on a 2-byte boundary; that is, it must have an even offset. Within an IFD, entries must be sorted in ascending tag order. A TIFF file must have at least one IFD and each IFD must have at least one entry. All offsets are absolute (from the beginning of the file header), not relative offsets from some other point within the file.

Each IFD entry starts with a 2-byte identifier, or *tag*. (The term *TIFF field* has been used to refer to an IFD entry or an IFD entry plus the associated value. The term *TIFF tag* has been used to refer to just the numeric ID or as a synonym for TIFF field. Here, *tag* is used for the numeric ID.) The entry then gives the data type for the value, then either the value itself or a pointer to it.

Table 11 shows the content of each 12-byte IFD entry:

Table 11 — IFD entry content

Offset, length	Description
0, 2 bytes	The TIFF tag, a numeric identifier. Tag identifiers for individual properties are listed in the TIFF and Exif specifications, and in 3, “ Digital photography native metadata ”.

Table 11 — IFD entry content (Continued)

Offset, length	Description
2, 2 bytes	<p>The value data type. One of:</p> <ul style="list-style-type: none"> • 1, BYTE, An 8-bit unsigned integer • 2, ASCII, An 8-bit byte with a 7-bit ASCII character • 3, SHORT, A 16-bit unsigned integer • 4, LONG, A 32-bit unsigned integer • 5, RATIONAL, A pair of LONGs, numerator then denominator • 6, SBYTE, An 8-bit signed integer • 7, UNDEFINED, An undefined 8-bitbyte • 8, SSHORT, A 16-bit signed integer • 9, SLONG, A 32-bit signed integer • 10, SRATIONAL, A pair of SLONGs, numerator then denominator • 11, FLOAT, A 4-byte IEEE floating point value • 12, DOUBLE, An 8-byte IEEE floating point value
4, 4 bytes	<p>The length, which is the number of values; depending on the data type, it is not necessarily the number of bytes. For the ASCII type, it is the number of characters. This is the exact number; it does not include any padding for odd lengths.</p> <p>An ASCII value must have a terminating NULL (0x00) character, which is included in the count. An ASCII value can have multiple NULL terminated strings; the count is the total for all of the strings. Individual strings, other than the first, might begin on odd offsets.</p>
8, 4 bytes	<p>The value itself or a pointer to it:</p> <ul style="list-style-type: none"> • Small values (4 bytes or less) must be placed directly in the IFD entry. If less than 4 bytes, the value is placed in the lower numbered bytes. • For larger values, this is the byte offset that points to the data block. The offset must be even, but may otherwise point anywhere in the file regardless of IFD or IFD entry order.

Each directory entry represents either an individual metadata property, or a pointer to a block of metadata in another format. For tags that identify blocks of metadata in other formats, including XMP, the entry provides a length/offset pair that points to the data block. [Table 7](#) lists these tags:

Table 12 — Tags that identify metadata blocks

Tag	Hex	Usage
700	0x2BC	XMP packet
33723	0x83BB	IPTC dataset
34377	0x8649	Photoshop Image Resources (PSIR) containing non-metadata resources, and possibly duplicating the IPTC metadata
34665	0x8769	Exif subsidiary IFD offset
34853	0x8825	GPS subsidiary IFD offset

Table 7 shows the IFD entry for XMP:

Table 13 — IFD entry for XMP

Byte offset	Field value	Field name	Comments
0	700	TAG	Tag that identifies the field (decimal value).
2	1	Field type	The field type should be UNDEFINED (7) or BYTE (1).
4		Count	The total byte count of the XMP packet.
8		Value or Offset	The byte offset of the XMP packet, which must be encoded as UTF-8.

NOTE TIFF, JPEG, and PSD share complex issues of how native metadata formats are stored; see 2.4, “Native metadata in digital photography formats”.

Official documentation for the TIFF file format is available from: <http://partners.adobe.com/public/developer/tiff/index.html>

For reference information, see the TIFF 6.0 Specification: <http://partners.adobe.com/public/developer/en/tiff/TIFF6.pdf>

1.1.7 SVG (Scalable Vector Graphics)

SVG (Scalable Vector Graphics) is an XML-based vector image format for two-dimensional graphics with support for interactivity and animation. SVG file must have a ‘svg’ element having namespace <https://www.w3.org/2000/svg>. As SVG is a XML based file format, xmp uses XML Parser for handling SVG files. XMP Packet is placed inside the ‘metadata’ tag of outer ‘svg’ element. This ‘metadata’ element could be present anywhere inside the file. The ‘metadata’ tags could have other metadata in any form. But XMP will not handle any such non-xmp metadata.

Sample SVG tag hierarchy (not in any particular order)

```

<svg>                                <!-- Start of SVG tag -->
  <title/>                             <!-- title of SVG file (native metadata) -->
  <desc/>                               <!-- description of SVG file (native metadata) -->
  <metadata>                            <!-- all the metadata available in SVG file -->
  <x:xmpmeta/>                          <!-- XMP metadata available in SVG file -->
  <...>
  <...>
  </metadata>
  <...>                                <!-- SVG file content available as XML tags -->
  <...>
</svg>                                <!-- End of SVG tag -->

```

Only title and description of the whole document are being reconciled with the XMP packet. While reading from SVG files, native title and description would get higher precedence over XMP information but with a limitation that reconciliation would be done only with non-markup ‘title’ and ‘desc’ child of outer ‘svg’ element. While writing back into a file, title and description are being updated into the file.

Table 14 — List of properties for Reconciliation

Property name	Tag in SVG	XMP namespace	XMP name
Title	<title>.....</title>	dc	title
Description	<desc>....</desc>	dc	description

The recommended order of tags for SVG file is:

```
<title> ...</title>
<desc>...</desc>
<metadata>...</metadata>
```

In case if the file has different order than as specified above then order of tags would not be changed. New title and description child would be created under the outer svg element if the outer svg element don't have any such element.

NOTE Only UTF-8 encoded SVG files are currently supported. Compressed SVG files are not supported.

For reference information, see
SVG standard specifications: <https://www.w3.org/TR/SVG/>
XML specifications: <https://www.w3.org/TR/REC-xml/>

1.2 Dynamic media formats

Certain video formats have special considerations and are collected separately; see 1.3, “Video package formats”. These are presented here alphabetically:

- ASF (WMA, WMV)
- FLV (Flash® Video)
- IFF/RIFF (AVI, WAV, AIFF)
 - RIFF (AVI, WAV)
 - AIFF
- MOV (QuickTime)
- MP3
- MPEG-2
- MPEG-4 (generic and F4V)
- SWF (Flash)

1.2.1 ASF (WMA, WMV)

Advanced Systems Format (formerly Advanced Streaming Format) is Microsoft's proprietary digital audio/digital video container format, especially meant for streaming media. ASF is part of the Windows Media framework. The most common filetypes contained within an ASF file are Windows Media Audio (WMA) and Windows Media Video (WMV). WMA and WMV are very similar.

The file extension of an ASF file indicates what kind of compression is used for the content:

- An ASF file that contains audio content compressed with the WMA codec typically uses the .wma extension.
- An ASF file that contains audio content, video content, or both, compressed with WMA and WMV codecs uses the .wmv extension.

- Content that is compressed with any other codec use the generic .asf extension.

NOTE Software developers must carefully read the licensing terms in the ASF specification. Microsoft grants royalty-free permission to distribute executable and object code products that implement ASF support, but explicitly forbids distribution of source code.

The ASF specification is available at: <http://www.microsoft.com/windows/windowsmedia/forpros/format/asfspec.aspx>

1.2.1.1 ASF format

ASF files are logically composed of three types of top-level objects: Header, Data and Index Objects. A top-level object can contain other objects in its data section.

- The Header Object is mandatory and must be at the beginning of every ASF file.
- The Data Object is also mandatory and must immediately follow the Header Object.
- The Index Objects are optional, when present they must be the last objects in the ASF file.
- Other objects can appear between the Data Object and the first Index Object. XMP is embedded as one of these.

Figure 3 shows ASF format.

Figure 3 — ASF format

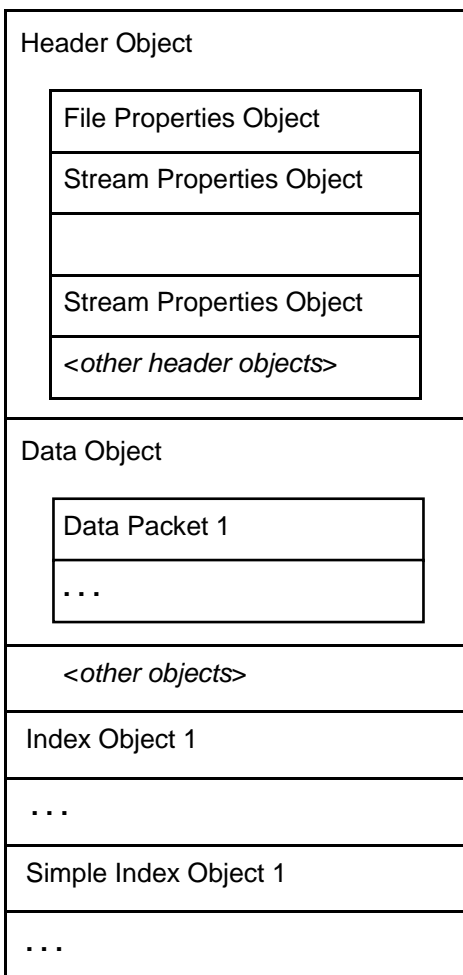

All ASF objects have a similar structure:

- A 16-byte GUID: The GUID identifies the purpose of an object. It is unique as a type identifier, not as an instance identifier; that is, the same conceptual object in different files has the same GUID. The ASF specification contains tables of standard GUIDs, and applications can create others. The ASF specification does not define GUIDs in file byte order. The documentation lists them as though they contained:
 - A 4-byte little-endian integer
 - A 2-byte little-endian integer
 - A 2-byte little-endian integer
 - A 2-byte big-endian integer
 - A 6-byte in-order sequence

Thus, if the documented value of a GUID is 00112233-4455-6677-8899-AABBCCDDEEFF, the file contains 33221100 55447766 8899AABB CCDDEEFF.

- An 8-byte little-endian size: The size includes both the GUID and size itself; that is, 24 plus the data size. The ASF specification does not say whether the size is signed or unsigned. For safety, it should be treated as unsigned, with a 63-bit range.
- The object's data

There appear to be no uses in ASF of relative offsets between objects, and no uses of absolute offsets of objects. Index offsets are relative to the appropriate data packet origin. This allows Header and XMP objects to be inserted, grown, or shrunk with relative ease. Only adjustments to the length of containing objects are necessary.

The ASF Header Object contains several nested objects that have native metadata fields mapped to XMP: See details of reconciliation in [2.3.1, "Native metadata in ASF \(WMA, WMV\) formats"](#).

1.2.1.2 XMP embedded in ASF

XMP is embedded in ASF as an "Other" top-level object. The GUID in ASF notation is:

```
BE7ACFCB-97A9-42E8-9C71-999491E3AFAC
```

The GUID in file byte order is:

```
CBCF7ABE A997E842 9C719994 91E3AFAC
```

The data of the XMP object is the XMP packet, using UTF-8 encoding.

FLV (Flash® Video)

FLV is designed to carry synchronized audio and video streams, and is used to deliver video over the Internet using Adobe Flash Player (in versions later than 6). Flash Video content may also be embedded within SWF files.

FLV is a fairly simple format, with a strong orientation to streaming use. It consists of a small file header then a sequence of tags that can contain audio data, video data, or ActionScript data. For FLV version 1, each tag begins with an 11-byte header:

- UI8 tag type: 8 = audio tag, 9 = video tag, 18 = script data tag
- UI24 content length in bytes
- UI24 time: low-order 3 bytes
- UI8 time: high-order byte
- UI24 stream ID

This is followed by the tag's content, then a UI32 "back pointer" which is the header size plus the content size. A UI32 zero is placed between the file header and the first tag as a terminator for backward scans. The time in a tag header is the start of playback for that tag. The tags must be in ascending time order. For a given time it is preferred that script data tags precede audio and video tags. Each audio or video tag typically contains one frame of data.

For metadata purposes, only the script data tags are of interest. Script data information becomes accessible to ActionScript at the playback moment of the script data tag through a call to a registered data handler. The content of a script data tag contains a string and an ActionScript data value. The string is the name of the handler to be invoked, the data value is passed as an ActionScript Object parameter to the handler.

A variety of native metadata is contained in a script data tag with the name `onMetaData`. This contains only internal information such as duration or width/height, nothing that is user- or author-editable, such as title or description. Some of these native items are imported into the XMP; none are updated from the XMP.

1.2.1.3 Placement of XMP

XMP is embedded in FLV as a script data tag with the name `onXMPData`. It must be placed at time 0 and must have stream ID 0. It should be after any time 0 `onMetaData` tag, and before any time 0 audio or video tags.

Software looking for existing XMP must examine all time 0 tags. One cannot presume that all third party modifiers of FLV files will preserve `onMetaData`, then `onXMPData`, then audio/video ordering.

The data value for `onXMPData` is an ECMA array. Standard serialized XMP is in an array item with the key `liveXML`; the data of this item is an ActionScript string containing a normal UTF-8 XMP packet (including padding). The ActionScript string can be a short or long string as appropriate.

The formal specification for SWF and FLV is *Macromedia Flash (SWF) and Flash Video (FLV) File Format Specification Version 8*. This is available at: <http://www.adobe.com/licensing/developer>

NOTE In the public FLV specification version 8 and earlier, there are errors in the descriptions of `SCRIPTDATAOBJECT`, `SCRIPTDATAOBJECTEND`, `SCRIPTDATAVARIABLE`, `SCRIPTDATASTRING`, `SCRIPTDATALONGSTRING`, `SCRIPTDATADATE`, ECMA arrays, and strict arrays.

1.23 IFF/RIFF (AVI, WAV, AIFF)

Formats based on IFF include RIFF, on which AVI and WAV are based, and AIFF. RIFF uses little-endian byte order, while [AIFF](#) uses big-endian byte order.

1.23.1 RIFF (AVI, WAV)

RIFF is based on IFF, and uses little-endian byte order. AVI and WAV are both based on the RIFF file format, but are not otherwise similar. RIFF was created in 1991 by Microsoft and IBM, and there seem to be no actively maintained file-format specifications. RIFF is a chunky format: a chunk has a 4 byte ID, a 4-byte length, and content. The ID is ASCII text, documented in file order. The length is unsigned, little-endian, and is just the content length. A zero-pad byte follows the content if the length is odd.

Some RIFF chunks are containers of other chunks. The content of a container (not a formal term) is a 4-byte ID followed by a sequence of nested chunks.

A normal RIFF file as a whole has an outer container chunk with an outer ID of "RIFF" and an inner ID that defines the file type. That is, the whole file is one chunk with the ID "RIFF", and that chunk is a container whose content begins with an ID for the file type followed by the "real" file structure. For AVI the inner ID is "AVI", for WAV the inner ID is "WAVE".

Another standard container is the "LIST" chunk. This is the normal grouping mechanism, used to create a tree structure instead of a single flat sequence of top level chunks.

The XMP in AVI and WAV is in a chunk with the ID "_PMX", encoded as UTF-8. Note that the ID is backwards, due to a bug in the initial implementation concerning processor byte order. The XMP chunk is immediately within the outermost "RIFF" chunk. There is no ordering constraint of the XMP relative to other chunks.

Although the RIFF format appears to have a 4 GB overall size limit, larger files are possible for AVI. This is done by writing a sequence of RIFF chunks. The first has an ID of "AVI ", the others have an ID of "AVIX". In addition, because of bugs in early AVI implementations, the outer RIFF chunks are commonly limited to 1 GB or 2 GB. The XMP chunk can be placed in any of the outer RIFF chunks, according to local criteria at the time the file is written.

The Library of Congress Digital Preservation project has general RIFF information at: <http://www.digitalpreservation.gov/formats/fdd/fdd000025.shtml> This includes a link to an HTML version of "Multimedia Programming Interface and Data Specifications 1.0": http://www.tactilemedia.com/info/MCI_Control_Info.html

1.2.3.1.1 AVI

AVI (Audio-Video Interleaved) is a multimedia container format. AVI files can contain both audio and video data in a standard container that allows synchronous audio-with-video playback.

AVI files can contain native metadata. See detail of how these are reconciled with XMP in 2.3.2, "Native metadata in IFF/RIFF (AVI, WAV, AIFF) formats".

The Library of Congress Digital Preservation project has specific AVI information at: <http://www.digitalpreservation.gov/formats/fdd/fdd000059.shtml> This includes a link to OpenDML extensions at: <http://www.morgan-multimedia.com/download/odmlff2.pdf>

1.2.3.1.2 WAV

WAV (or WAVE), short for Waveform audio format, is a Microsoft and IBM audio file format standard for storing audio on PCs. It is the main format used on Windows systems for raw audio.

WAV is based on of the RIFF format for storing data in chunks. WAV has a single outer RIFF chunk, with the ID "WAV" The XMP is part of the RIFF/WAV chunk with the ID "_PMX". WAV files over 4 GB can be stored in the RF64 file format, developed by the European Broadcast Union (<http://tech.ebu.ch/docs/tech/tech3306-2009.pdf>).

WAV files can contain native metadata; see details of reconciliation with XMP in 2.3.2, "Native metadata in IFF/RIFF (AVI, WAV, AIFF) formats".

The Library of Congress Digital Preservation project has specific WAV information at: <http://www.digitalpreservation.gov/formats/fdd/fdd000001.shtml>

1.2.3.2 AIFF

The Audio Interchange File Format (Audio IFF) provides a standard for storing sampled sounds. AIFF-C adds the ability to store compressed audio data in a standard manner.

AIFF, like RIFF, is based on IFF. AIFF uses big-endian byte order, while RIFF uses little-endian byte order. The main container chunk for AIFF is called "FORM" (rather than 'RIFF') with the same format as the 'RIFF' container; see 1.2.3.1, "RIFF (AVI, WAV)". The type of AIFF files is always 'AIFF' and AIFF_C files use 'AIFC' as form identifier.

XMP is stored as an "Application Specific Chunk" with the Application Signature 'XMP':

```
Byte Nr  1234 5678 9...
        APLL size 'XMP ' <?xpacket ...
```

In order to keep the original ordering of chunks, free space is used to fill the space of a moved XMP chunk (or text chunk). The free space is defined as "Application Specific Chunks" with the signature 'FREE' and is filled with '0'. The minimum size of such a free chunk is 12 bytes (4 bytes ID, 4 bytes size, 4 bytes type). Smaller free space can be created with ANNO chunks (Annotation Text Chunks) filled with 0. These 'empty' annotation chunks should be ignored by other software.

AIFF and AIFF-C can contain native metadata; see details of reconciliation with XMP in [2.3.2.3, "Native metadata in AIFF"](#).

The AIFF specifications are available at

<http://www-mmsp.ece.mcgill.ca/Documents/AudioFormats/AIFF/Docs/AIFF-1.3.pdf>

<http://www-mmsp.ece.mcgill.ca/Documents/AudioFormats/AIFF/Docs/AIFF-C.9.26.91.pdf>

1.2.4 MOV (QuickTime)

The QuickTime MOV file format was developed by Apple as a container for a wide variety of dynamic media including sound, video, and animation. It functions as a multimedia container file that contains one or more tracks, each of which stores a particular type of data: audio, video, effects, or text (for subtitles, for example). Each track either contains a digitally-encoded media stream (using a specific codec) or a data reference to the media stream located in another file. Tracks are maintained in a hierarchical data structure consisting of objects called *atoms*.

The basic structure of a QuickTime file is similar to the RIFF format used by AVI and WAV. QuickTime was used as the basis of the MPEG-4 format, ISO/IEC 14496-14.

The basic unit of a QuickTime file, the atom, is similar to the "chunks" in RIFF. An atom can either be a leaf atom containing data, or a container atom containing other atoms. There is no structural indication of a leaf or container atom, this is implicit in the atom's type. Other than nesting rules, there is generally no necessary ordering among atoms.

All atoms begin with a standard or extended header. The standard header has a 32-bit big-endian unsigned length followed by a 32-bit type code. The type codes are almost always 4 ASCII characters, but a few special cases exist (such as 0x00000001). The size field gives the atom's total size, including the 8-byte header. If the initial size field is set to 1, a 64-bit big-endian size follows the standard header, forming an extended header.

Although QuickTime and MPEG-4 are related formats, older QuickTime files do not contain the top-level 'ftyp' atom that is compulsory for MPEG-4. Newer QuickTime files might contain an 'ftyp' atom, with "qt " in the compatible brands. These files should be treated as QuickTime, not generic MPEG-4.

1.2.4.1 Placement of XMP

XMP is stored in QuickTime as an "XMP_" atom, within a "udta" atom, within a top level "moov" atom. The XMP atom's content is the XMP packet, using UTF-8 encoding.

The formal specification for the QuickTime file format is available at: <http://developer.apple.com/reference/QuickTime/idxFileFormatSpecification-date.html>

1.2.5 MP3

MPEG-1 Audio Layer 3, more commonly referred to as MP3, is a popular audio encoding format. MPEG stands for Moving Picture Experts Group. The formal standard is ISO/IEC IS 11172-3, but this only covers the raw audio aspects. The metadata in MP3 files uses the ID3v1 or ID3v2 format. When used with XMP, this must be ID3v1, ID3v2, ID3v2.3 or ID3v2.4. The ID3v2.3 and ID3v2.4 formats are almost identical. The most notable difference is that ID3v2.4 allows text values to be UTF-8, in addition to ISO 8859-1 (Latin-1) or UTF-16.

The entire ID3 portion of the MP3 file is called the ID3 "tag" (rather confusingly, given other media file and metadata terminology). The individual metadata items are called ID3 "frames".

1.2.5.1 Placement of XMP

The XMP is placed within the ID3 as a "PRIV" frame with an Owner identifier of "XMP". The content of the XMP PRIV frame is the XMP packet, encoded as UTF-8.

MP3 files can contain native metadata; see detail of reconciliation with XMP in 2.3.3, "Native metadata in MP3".

Specifications can be found at:

- <http://www.id3.org/id3v1>
- <http://www.id3.org/id3v2-00>
- <http://www.id3.org/id3v2.3.0>
- <http://www.id3.org/id3v2.4.0-structure>

1.2.6 MPEG-2

MPEG-2 is a standard for the generic coding of moving pictures and associated audio information. It describes a combination of lossy video compression and lossy audio compression (audio data compression) methods which permit storage and transmission of movies using currently available storage media and transmission bandwidth. It is not the same as MPEG-1 Audio Layer II (MP2).

MPEG-2 is a common format for standard definition digital video. It is used for DVD discs, by DV camcorders, for terrestrial (over the air) broadcast, for cable, and direct broadcast satellite. The formal specification for MPEG-2 is ISO/IEC 13818.

XMP is not directly embedded within MPEG-2 files, but is specified as a *sidecar file*. This is a separate file containing just the XMP packet, which is stored at the same location as the MPEG-2 file, and uses the same file name, with the file extension .xmp replacing the original file extension.

1.2.7 MPEG-4 (generic and F4V)

MPEG-4 is a collection of methods defining compression of audio and visual (AV) digital data. MPEG-4 absorbs many of the features of MPEG-1 and MPEG-2 and other related standards, adding new features such as (extended) VRML support for 3D rendering, object-oriented composite files (including audio, video and VRML objects), support for externally-specified Digital Rights Management and various types of interactivity. AAC (Advanced Audio Codec) was standardized as an adjunct to MPEG-2 (as Part 7) before MPEG-4 was issued.

The file format is defined by parts 12 and 14 of ISO 14496. Part 12 defines the "ISO Base Media File Format", which happens to also be used by JPEG 2000 (ISO 15444). Part 14 describes MPEG-4 specific aspects.

An MPEG-4 file can be identified by the very first box being a 'ftyp' one that contains one of the four compatible brands: 'mp41', 'mp42', 'f4v ', or 'avc1'.

Although MPEG-4 and QuickTime are related formats, older QuickTime files do not contain the top-level 'ftyp' box that is compulsory for MPEG-4. Newer QuickTime files might contain an 'ftyp' box, with "qt " in the compatible brands. These files should be treated as QuickTime, not generic MPEG-4.

1.2.7.1 Placement of XMP

XMP is embedded in MPEG-4 files in the same manner as in JPEG 2000, using a top-level UUID box. A well-formed file contains at most one XMP UUID box, but this is not normally verified. The UUID for both is:

```
BE7ACFCB 97A942E8 9C719994 91E3AFAC
```

The remainder of the box is a typical XMP packet, encoded as UTF-8, including packet wrapper and padding.

MPEG-4 files can contain native metadata; see detail of reconciliation with XMP in 2.3.4, “Native metadata in MPEG-4”.

1.2.8 SWF (Flash)

SWF is a proprietary vector graphics file format produced by the Flash software from Adobe. Intended to be small enough for publication on the web, SWF files can contain animations or applets of varying degrees of interactivity and function. SWF is also sometimes used for creating animated display graphics and menus for DVD movies, and television commercials.

SWF was designed to deliver vector graphics, text, video and sound over the Internet. The SWF file format is designed to be an efficient delivery format, not a format for exchanging graphics between graphics editors. SWF is quite different from the Flash Video file format, FLV. FLV is designed to carry synchronized audio and video streams (see 1.2.2, “FLV (Flash® Video)”).

An SWF file consists of a file header followed by a sequence of tagged data blocks, called *tags*. The tags share a common format, so any program parsing a SWF file can skip blocks it does not understand. Data inside the block can point to offsets within the block, but can never point to an offset in another block. This enables tags to be removed, inserted, or modified by tools that process a SWF file.

SWF files always store integers in little-endian byte order. The common tag structure is very simple, a short or long tag header followed by the data. The short header is a 16-bit little-endian unsigned integer. The upper 10 bits are the tag's type code, the lower 6 bits are the length of the data. If the data is 63 bytes or longer, a long tag header is used. This is a short header with a length value of 63 (0x3F), followed by a 32-bit little-endian integer giving the actual data length.

Beginning with SWF 8, a FileAttributes tag is required immediately after the file header.

1.2.8.1 Placement of XMP

XMP is supported beginning with SWF 8. There are two aspects to placing XMP in SWF:

- A flag in the FileAttributes tag denoting whether the file contains XMP.
- A tag containing the XMP.

The FileAttributes tag has a type code of 69. The tag data is 4 bytes containing several variable-length bit fields. Counting bits from the low-order end, the HasMetadata flag is bit 4 of the first byte; that is, the mask 0x10 selects the HasMetadata flag from the first byte. This flag must be set if and only if the file contains XMP.

The XMP tag (called the Metadata tag) has type code 77. The tag data is the serialized XMP, using UTF-8 encoding. It is best to omit the XMP packet wrapper (including padding) to save space. Similarly, you should use RDF shorthand and omit formatting whitespace.

The formal specification for SWF and FLV is "Macromedia Flash (SWF) and Flash Video (FLV) File Format Specification Version 8." This is available at: <http://www.adobe.com/licensing/developer>

NOTE The SWF specification (not this XMP Specification) is the authority for how XMP is embedded in SWF.

1.3 Video package formats

Certain video formats have special considerations. In these formats a video entity (a movie) consists of a collection, or package, of related files of various types—audio, video, voice, and so on. In video package formats, the document unit is called a *clip*. Information for an individual clip is stored in multiple files, in a directory structure defined by the format specification. XMP metadata relates to the clip as a whole, rather than to individual files, and is stored in its own file for the associated clip.

These folder-oriented formats use shallow trees with specific folder names and highly stylized file names. The user thinks of the tree as a collection of clips, consisting of multiple files for video, audio, metadata, and so on. For example, a portion of a P2 folder might look like this:

```
.../MyMovie
  CONTENTS
    CLIP
      0001AB.XML
      0002CD.XML
    VIDEO
      0001AB.MXF
      0002CD.MXF
    VOICE
      0001AB.WAV
      0002CD.WAV
```

The user thinks of .../MyMovie as the container of P2 video, which in this case contains two clips identified with a file base name of 0001AB and 0002CD. Each clip is stored as a collection of files, each file holding some specific aspect of the clip's data. The exact folder structure and file layout differs, but the basic concepts carry across all of the folder-oriented video-package formats.

NOTE The folder layout descriptions here are meant to show typical usage and describe where XMP files are found; they are not meant to be complete or definitive package format descriptions.

- [AVCHD](#)
- [P2](#)
- [Sony HDV \(High Definition Video\)](#)
- [XDCAM](#) (several variations)

1.3.1 AVCHD

AVCHD (Advanced Video Codec High Definition) is a high-definition video recording format for use in digital tapeless camcorders. The format is comparable to other handheld video camera recording formats, particularly TOD, HDV and MiniDV.

A typical AVCHD package layout looks like this:

```
BDMV/
  index.bdmv
  MovieObject.bdmv
  PLAYLIST/
    xxxxx.mpls
  STREAM/
    zzzzz.m2ts
    zzzzz.xmp
  CLIPINF/
    zzzzz.clpi
  BACKUP/
```

A base name with a numeric sequence distinguishes files belonging to the same clip. The XMP is placed in the STREAM folder, using the clip base name and the extension XMP. For example if the playlist name (xxxxx) 00001 and the clip name (zzzzz) is 00002, the files 00002.m2ts and 00002.clpi belong to clip 2. The related metadata for the clip is 00002.xmp.

1.3.2 P2

A P2 card is a solid-state memory device that plugs into the PCMCIA slot of a Panasonic P2 video camera, such as the AG-HVX200. The digital video and audio data from the video camera is recorded onto the card in a

structured, codec-independent format known as MXF (Media eXchange Format). A clip is said to be in the P2 format if its audio and video are contained in Panasonic Op-Atom MXF files, and these files are located in a specific file structure.

The root of the P2 file structure is a CONTENTS folder. Each *essence* item (an item of video or audio) is contained in a separate MXF wrapper file; the video MXF files are in the VIDEO subfolder, and do on. The relationships between essence files and the metadata associated with them are tracked by XML files in the CLIP subfolder.

A typical P2 layout looks like this:

```
.../MyMovie
  CONTENTS/
    CLIP/
      0001AB.XML
      0001AB.XMP
      0002CD.XML
      0002CD.XMP
    VIDEO/
      0001AB.MXF
      0002CD.MXF
    AUDIO/
      0001AB00.MXF
      0001AB01.MXF
      0002CD00.MXF
      0002CD01.MXF
    ICON/
      0001AB.BMP
      0002CD.BMP
    VOICE/
      0001AB.WAV
      0002CD.WAV
    PROXY/
      0001AB.MP4
      0002CD.MP4
```

This shows two clips whose file base names are 0001AB and 0002CD.

A base name with a numeric sequence distinguishes files belonging to the same clip. The XMP is placed in the CLIP folder, beside the .XML file that defines the existence of the clip. The .XML file contains a variety of information about the clip, including some native metadata.

The XMP is stored using the clip base name and the extension XMP. In the example, the file 0001AB.XMP contains the metadata associated with the clip defined by 0001AB.XML.

1.3.3 Sony HDV (High Definition Video)

A typical Sony HDV layout looks like this:

```
.../MyMovie/
  VIDEO/
    HVR/
      00_0001_2007-08-06_165555.IDX
      00_0001_2007-08-06_165555.M2T
      00_0001_2007-08-06_165555.XMP
      00_0001_2007-08-06_171740.IDX
      00_0001_2007-08-06_171740.M2T
      00_0001_2007-08-06_171740.XMP
      tracks.dat
```

This shows two clips with the same base name, but different time stamps. The .IDX file defines the existence of the clip. XMP is stored in a file with the clip base name, the date/time suffix from the associated .IDX file, and the .XMP extension.

1.3.4 XDCAM

These package formats are used by various models of the Sony XDCAM line of high-definition disc video camcorders.

NOTE Sony documentation uses mixed-case folder names "General", "Clip", "Sub", and "Edit". The names are shown in all caps here.

1.3.4.1 XDCAM EX

A typical XDCAM EX package layout looks like this:

```
.../MyMovie/
  BPAV/
    MEDIAPRO.XML
    MEDIAPRO.BUP
    CUEUP.XML
    CUEUP.BUP
    CLPR/
      709_001_01/
// MI_XXXX_YY: MI is MachineID, XXXX is TakeSerial, YY is ClipSuffix
// (a single take can be divided across multiple clips.)
      709_001_01.SMI
      709_001_01.MP4
      709_001_01M01.XML
// last counter from 01-99 based on number of files with the same extension
// that are in this folder
      709_001_01M01.XMP
      709_001_01R01.BIM
      709_001_01I01.PPN
      709_001_02/
      709_002_01/
      709_003_01/
    TAKR/
      709_001/
      709_001.SMI
      709_001U01.SMI
// last counter is 01 to N-1, where N is number of media in this take
// (in this example the take includes 709_001_01 and 709_001_02)
// For Nth (2nd, CLPR/709_001_02), MIXXXX.SMI is used (709_001.SMI)
// U means "unfinished"
      709_001M01.XML
// MI_XXXXMMN counts from 01-99 based on number of clips in this take.
```

Backup files (.BUP) are optional. No files or directories other than those listed are allowed in the BPAV directory. The CLPR (clip root) directory may contain only clip directories, which may only contain the clip files listed.

The CLPR (clip root) folder contains clip subfolders, whose name is the base file name for that clip. Each clip folder contains a media file (.MP4), a clip information file (.SMI), a real-time native metadata file (.BIM), a non-real-time native metadata file (.XML), and a picture pointer file (.PPN).

- XMP metadata is stored in the.XMP file within a clip directory, using the same base name as the XML file.

A take directory contains a take info and non-real-time take metadata files.

The TAKR (take root) directory may contain only take directories, which may only contain take files. The take root directory can be empty.

MEDIAPRO.XML contains information on clip and take management.

1.3.4.2 XDCAM SAM

A typical SAM layout looks like this:

```
.../MyMovie/  
  GENERAL/  
    unknown files  
  PROAV/  
    INDEX.XML  
    INDEX.BUP  
    DISCMETA.XML  
    DISCINFO.XML  
    DISCINFO.BUP  
    CLPR/  
      C0001/  
        C0001C01.SMI  
        C0001V01.MXF  
        C0001A01.MXF  
        C0001A02.MXF  
        C0001R01.BIM  
        C0001I01.PPN  
        C0001M01.XML  
        C0001M01.XMP  
        C0001S01.MXF  
      C0002/  
        ...  
    EDTR/  
      E0001/  
        E0001E01.SMI  
        E0001M01.XML  
      E0002/  
        ...
```

The CLPR/ folder contains a subfolder for each clip, which use the base file name. This example shows two clips, with base names C0001 and C0002. The EDTR/<edit list> folder contains the edit list file (.SMI), which uses different clips, and a native metadata file (.XML) related to the edit list.

A clip file and its related XMP are kept together in the CLPR/<clip> folder.

- The .XML file defines the existence of the clip. The name uses the base clip name plus additional identifying characters. It contains a variety of information about the clip, including some native metadata.
- The .XMP file with the same base file name as the XML file contains the XMP for the clip.

1.3.4.3 XDCAM FAM

A typical FAM layout looks like this:

```
.../MyMovie/  
  INDEX.XML  
  DISCMETA.XML  
  MEDIAPRO.XML
```

```

General/
    unknown files
Clip/
    C0001.MXF
    C0001M01.XML
    C0001M01.XMP
    C0002.MXF
    C0002M01.XML
    C0002M01.XMP
Sub/
    C0001S01.MXF
    C0002S01.MXF
Edit/
    E0001E01.SMI
    E0001M01.XML
    E0002E01.SMI
    E0002M01.XML
Local/          // optional
    C0001C01.SMI
    C0001C01.PPN

```

The top-level folder MyMovie/ contains XDCAM data for two clips whose raw names are C0001 and C0002. The CLIP folder contains at least one .XML file that defines the existence of a clip with that base file name.

A clip file and its related XMP are kept together in the Clip folder. Any related Subclip is present in the folder. The Edit folder contains the Edit list files. Content related files are optionally present in the Local folder.

- The .XML file defines the existence of the clip. The name uses the base clip name plus additional identifying characters. It contains a variety of information about the clip, including some native metadata.
- The .XMP file with the same base file name as the XML file contains the XMP for the clip.

1.3.4.4 XDCAM FAM Memory SxS

This package format is used by certain models of the Sony XDCAM line of memory-card-based high-definition video camcoders. See also [1.3.4.2, "XDCAM SAM"](#).

A typical FAM Memory SxS layout looks like this:

```

.../MyMovie/
DISCMETA.XML
MEDIAPRO.XML
CUEUP.XML
General/
Clip/
    C0001.MXF
    C0001M01.XML
    C0001M01.XMP
    C0001R01.BIM
    C0002.MXF
    C0002M01.XML
    C0002M01.XMP
    C0001R01.BIM
Sub/
    C0001S01.MXF
    C0002S01.MXF
Edit/
Take/
    T0001.SMI

```

T0001M01.XML
UserData/

The top-level folder MyMovie/ contains XDCAM data for two clips whose raw names are C0001 and C0002.

The Clip folder contains at least one non-real time metadata .XML file that defines the existence of a clip with that base file name. The CLIP folder also contains a related media file .MXF , a real-time native metadata file .BIM and XMP metadata file .XMP , all of them using the same base name as XML file.

The Sub folder contains the sub-clip files and the 'Take' folder contains the a take-info file (.SMI) and a non-real time take metadata .XML file, for each take.

MEDIAPRO.XML contains information on the clip and take management.

1.4 Adobe application formats

- 1.4.1, "AI (Adobe Illustrator®)"
- 1.4.2, "INDD, INDT (Adobe InDesign®)"
- 1.4.3, "PSD (Adobe Photoshop)"

1.4.1 AI (Adobe Illustrator®)

An .ai file generated by Adobe Illustrator® is in the Portable Document Format (PDF). Hence, the format for embedding XMP metadata is the same as for PDF files.

1.4.2 INDD, INDT (Adobe InDesign®)

InDesign document files (.indd) and InDesign template files (.indt) are primarily paged database files. They have 4 KB pages with a leading pair of master pages to allow single write commits. The detailed structure of the database is proprietary.

Externally editable XMP is supported for database files from InDesign 2.0 and later through a "contiguous object" section at the end of the file. It is possible to modify, even extend, the XMP in the contiguous object section. It is not possible to add XMP to a database that has none without intimate knowledge of the database.

In brief, the active master page tells how many database pages the file contains. The contiguous object section begins after the last database page and extends to the end of the file. It contains copies of database objects, stored in a contiguous (nonpaged) manner.

Figure 4 shows the layout. In the figure:

- The curved arrow represents the fact that the current (active) master page indicates how many database pages there are, enabling an application to find the beginning of the contiguous object section.
- Main pages: This is the main part of the database file, comprised of 4 KB pages. The first two pages--the master pages--are used to determine how big this part of the file is (that is, where the contiguous object copies start). Otherwise, this data can be ignored when scanning for XMP data, and you should never alter this portion of the file if you are modifying XMP data.
- Contiguous objects: Following the data pages, copies of contiguous objects are written, and each has a special header and trailer. Here you would find any XMP objects, and you may rewrite this part of the file if you need to expand the file's XMP data beyond whatever padding is supplied in the XMP packet.
- Zero padding: The file is zero padded so that the file size is a multiple of 4 KB.

Figure 4 — InDesign file layout

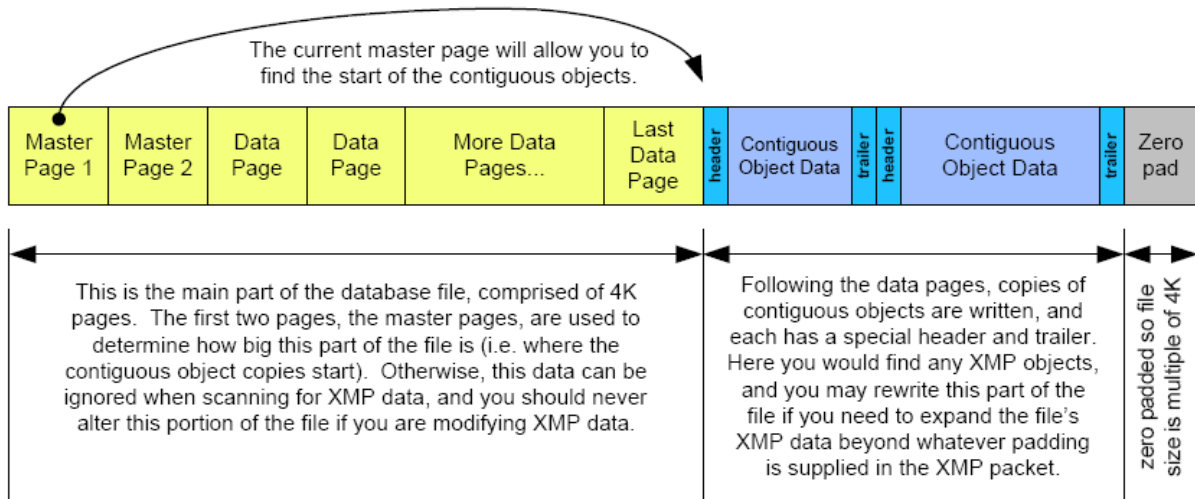

The majority of an InDesign database file consists of the 4 KB pages that comprise the transacted database storage. You can use the first two pages in the file, called the Master Pages, to determine whether contiguous objects are present, where they are, and whether they include any XMP metadata objects that contain XMP packets. InDesign document databases do typically contain XMP metadata, but this is not strictly required. Other types of InDesign files, such as book files, do not currently contain metadata.

- For details of the Master Page structure, see [1.4.2.3, "Master page structure"](#).
- For details of the Header and Trailer that enclose each contiguous object, see [1.4.2.4, "Header and trailer structure"](#)

1.4.2.1 Finding XMP in an InDesign file

To efficiently find XMP data when present in an InDesign database file:

- 1 Verify that the first 16 bytes of the file are the GUID for an InDesign database file.
- 2 Read the two Master Page sequence numbers, and decide which master page is the current one, which is the one with the larger sequence number.
- 3 Using `fFilePages` from the current master page, seek to absolute file position `fFilePages * 4096`. Remember that a database file may exceed 4 GB in size.
- 4 Search through the contiguous objects for an XMP packet. When the contiguous object you are examining is the persistent representation of an object that contains an XMP packet, the stream between the headers consists of a 4-byte integer specifying the length for the XMP packet, followed by the XMP packet itself.
 - The byte-order of the length integer is governed by the `fObjectStreamEndian` field from the master page. This is true *only* of this value; all integer values within the data are in little-endian order.
 - The packet header begins like this:

```
<?xpacket begin="W5M0MpCehiHzreSzNTczkc9d"
```

The quote characters can be double (") or single (').

1.4.2.2 Rewriting XMP data beyond the packet padding

The length value that precedes the packet header must equal `fStreamLength` (from the header and trailer) minus 4 bytes (for the length value itself). You should verify that this is true before attempting to rewrite the XMP packet, and thus rewrite the length value. If the first four-byte integer in the stream (interpreted using the

Master Page-specified byte order) is not `fStreamLength-4`, you should not enlarge the packet but simply use the padding if possible.

If you rewrite a contiguous object that contains an XMP packet, follow these rules:

- While looking for a contiguous object header beyond the paged part of the file (as directed by `fFilePages` in the master page), if you find something that is not a header GUID but not zero padding at the end of the file, assume that the file format has changed and fall back to default behavior.
- InDesign might store other contiguous objects in addition to XMP packets at the end of the file in the same way. The API that allows this is public, so a third-party developer might also store arbitrary objects there. If you rewrite an XMP packet, make sure you are changing only the object that contains your XMP packet, and preserve any other contiguous object copies you find at the end of the file.
- Verify that the XMP object you want to rewrite is marked externally writable in the contiguous object header (or trailer).
- Verify that the first four-byte integer (variable endian) in the XMP object stream is indeed the length of the XMP packet immediately following, and that this value is the header's (or trailer's) `fStreamLength - 4`.
- When you rewrite the XMP object, rewrite the header and trailer for the XMP object with an `fChecksum` field of `0xffffffff` and an updated `fStreamLength` field.
- The size in bytes of an InDesign database file is required to be a multiple of 4 KB. A file that violates this constraint is considered corrupt. If you are rewriting contiguous objects at the end of the file to expand an XMP packet, pad the file with zeros if necessary after the last contiguous object trailer to ensure this condition is met.

1.4.2.3 Master page structure

The following code shows the parts of the Master Pages of interest with respect to metadata:

```
struct MasterPage {
// 16 byte GUID identifying this as an InDesign database
// Must be: 0606EDF5-D81D-46e5-BD31-EFE7FE74B71D
char fGUID [16];
// 8 bytes; type of database (for example "DOCUMENT")
char fMagicBytes [8];
// Endian of object streams, 1=little endian, 2=big endian
char fObjectStreamEndian;
// Irrelevant stuff
char fIrrelevant1 [239];
// Master page sequence number. The master page with
// the larger value is the current master page
LittleEndianUnsignedInt64 fSequenceNumber;
// More irrelevant stuff
char fIrrelevant2 [8];
// The number of pages in the file. fFilePages * 4096
// is the absolute file offset in bytes of where any
// contiguous data storage would begin (provided this
// master page is the current master page).
LittleEndianUnsignedInt32 fFilePages;
// More irrelevant stuff
char fIrrelevant3 [3812];
};
```

Table 14 describes the fields in a master page.

Table 14 — Master page fields

fGUID	<p>The first 16 bytes of each master page (and thus the first 16 bytes of the file) are set to a GUID that identifies the file as an InDesign database.</p> <p>The ID value of the master page is: 0606EDF5-D81D-46e5-BD31-EFE7FE74B71D</p> <p>You must check for this value. If it is not present, something has changed in an incompatible way in the file format and you can make no further assumptions. You can search the entire file to find XMP metadata, but you cannot add additional metadata beyond any padding provided in the packet.</p>
fMagicBytes	<p>Contains an 8-byte sequence identifying the type of database file.</p> <p>This can be useful if you want this information and cannot get it from the file extension or type and creator. The 8 characters "DOCUMENT" designate a database that contains an InDesign document and would normally have a .indd extension.</p>
fObjectStreamEndian	<p>The byte order (big-endian or little-endian) in which integers in an object stream are written, which depends on the creation platform of the database.</p> <p>You must use this byte-order to interpret the packet-length value if you enlarge XMP packets and rewrite the file format; see 1.4.2.2, "Rewriting XMP data beyond the packet padding".</p> <p>You do not need it to find or interpret the XMP data; all integer values in the storage structures themselves are uniformly little-endian.</p>
fSequenceNumber	<p>The master page sequence number, a value that is incremented each time a new master page is written.</p> <p>To ensure data integrity, the current master page is written in an alternating fashion to the first two pages in the file. You must discover which master page of the pair is the current one by finding which has the larger sequence number. This integer field, like the others in the storage structures, is written in a standard little-endian form regardless of database creation platform.</p>
fFilePages	<p>The number of 4 KB pages (including the master pages) in the transacted database part of the file. To efficiently search for XMP metadata, seek to and read from the absolute file position 4096 * fFilePages.</p>

1.4.2.4 Header and trailer structure

The following code shows the parts of the Header and Trailer of a contiguous object that are of interest with respect to metadata:

```
struct ContiguousObjectStreamHeaderOrTrailer {
// 16 byte GUID identifying this as either a header or trailer
// Headers are: DE393979-5188-4b6c-8E63-EEF8AEE0DD38
// Trailers are: FDCEDB70-F786-4b4f-A4D3-C728B3417106
uint8 fGUID [16];
// UID of the corresponding object in the database
LittleEndianUnsignedInt32 fObjectUID;
// ClassID of the object. This object is externally
// writable if and only if fObjectClassID & 0x40000000 == 0x40000000.
LittleEndianUnsignedInt32 fObjectClassID;
// Length of the stream of data which is the persistent
// representation of the object. This is the size in
// bytes of the data between the header and trailer.
```

```

LittleEndianUnsignedInt32 fStreamLength;
// The ADLER32 checksum (see RFC1950) of the stream of
// data at the time it was last written by InDesign.
// InDesign only propagates externally writable contiguous
// objects back into the database when there is a checksum mismatch.
LittleEndianUnsignedInt32 fChecksum;
};

```

Table 15 shows the fields in the header and trailer

Table 15 — Fields in header and trailer of a contiguous object

fGUID	<p>A16-byte GUID identifying the structure as either a contiguous object header or trailer. This is the only difference between a header and trailer, which otherwise hold copies of the same information.</p> <ul style="list-style-type: none"> The header ID value is: DE393979-5188-4b6c-8E63-EEF8AEE0DD38 The trailer ID value is: FDCEDB70-F786-4b4f-A4D3-C728B3417106
fObjectUID	<p>The unique identifier of the original object in the database, whose persistent representation has a contiguous copy here at the end of the file.</p> <p>Because there is a one-to-one correspondence between object copies here at the end of the file and objects stored in the main database, you are not free to add an object containing an XMP packet if one does not exist. Also, removing a contiguous object copy will not result in the deletion of the corresponding database object when the file is next opened by InDesign; the best you could do to remove all metadata is rewrite an existing object to contain an XMP packet that is well formed but devoid of content.</p>
fObjectClassID	<p>Information about the object type, a set of bit flags. The second most significant bit of this field, when set, declares the object as externally writable.</p> <p>If you find an object containing an XMP packet but this bit is not set, changes to that object are not allowed and would not be propagated back into the database. InDesign makes all XMP objects writable.</p>
fStreamLength	<p>The number of bytes in the persistent representation of the object, which is also the number of bytes between the header and the trailer.</p> <p>If you are writing new headers and trailers because you are enlarging an XMP object, you need to update this field in the header and trailer. For an XMP object, this is the size of the XMP packet itself plus a 4-byte integer specifying the length of the XMP packet; see 1.4.2.2, “Rewriting XMP data beyond the packet padding”.</p>
fChecksum	<p>The ADLER32 (see RFC1950) checksum of the object stream (all data between header and trailer) at the time InDesign wrote it. InDesign uses this when it opens the database to check whether a contiguous object copy has changed, and the changes need to be propagated into the primary part of the database.</p> <p>If you rewrite an object, set the fChecksum field to 0xffffffff to ensure that a checksum mismatch occurs and InDesign recognizes your changes.</p>

1.4.3 PSD (Adobe Photoshop)

An Adobe Photoshop® .psd file is divided into five sections. The file header and image resource sections are important for metadata access. Multibyte integers are stored big-endian on all platforms.

Table 16 shows the file sections relevant to metadata:

Table 16 — PSD file sections relevant to metadata

File header	A 26-byte block; see Table 17. Only the signature and version fields affect metadata.
Color mode data	Contains a 4-byte length value, followed by the data.
Image resources	Used to store nonpixel data associated with an image. Begins at file offset 30 (26+4) plus the length of the color mode data. See Table 18, The section contains a 4-byte length value, followed by the data for all image resources. The length value is the total length of the image resource section, which is a sequence of individual image resources. The internal structure of an image resource is described in 3.2.1, “Photoshop image resources for metadata”. The TIFF and JPEG file formats can also contain Photoshop image resources, although the content varies according to what file format the resource is in.

TIFF, JPEG, and PSD share complex issues of how native metadata formats are stored; see 2.4, “Native metadata in digital photography formats”.

Table 17 — PSD file header block

Offset	Length	Description
0	4	File signature, must be "8BPS"
4	2	Version, 1 for normal files, 2 for "big" files. This distinction is primarily in the maximum image dimensions. There is no distinction between them for metadata parsing.
6	6	Reserved, must be zero
12	2	Number of channels
14	4	Image height in pixels
18	4	Image width in pixels
22	2	Number of bits per channel
24	2	Color mode

Table 18 — PSD image resource blocks

Field	Type	Description
Type	OStype	Adobe applications always uses the signature 8BIM. Other values can appear, and must be tolerated by readers.
ID	2 bytes	ID = 1060 for XMP metadata.
Name	PString	There is no name value in XMP image resources.

Table 18 — PSD image resource blocks (Continued)

Field	Type	Description
Size	4 bytes	Actual size of resource data. This does not include the Type, ID, Name, or Size fields.
Data	Variable	Resource data, padded to make the size even (that is, an extra zero byte is appended to the “raw” field value if needed). This is the XMP packet, which must be encoded as UTF-8.

Official documentation for the Photoshop file format is part of the Photoshop SDK. Information about the Photoshop SDK is available from: <http://partners.adobe.com/public/developer/photoshop/devcenter.html>

1.5 Markup formats

- 1.5.1, “HTML”
- 1.5.2, “XML”

1.5.1 HTML

XMP embedded in HTML should conform to one of the W3C recommendations for embedding XML in HTML. For reference information, see the meeting report for the May 1998 W3C meeting: <http://www.w3.org/TR/NOTE-xh>

XML can be embedded in a SCRIPT or XML element, placed in any legal location; the suggested location is the end of the HEAD element. The content of the SCRIPT or XML element is the XMP packet.

The browser must recognize the SCRIPT or XML element so that text representing the value of RDF properties is not displayed as page content. Using the XML element is preferred unless there are known incompatibilities with older software; if so, the SCRIPT element is likely to be recognized.

1.5.1.1 Embedding XML in HTML

There are three approaches to embedding XML in HTML, as shown in the examples below. Two use the SCRIPT element, and the third uses the XML element.

1.5.1.1.1 Using the SCRIPT element and LANGUAGE attribute

```
<html>
  <head>
    <SCRIPT LANGUAGE="XML">
      <?xpacket begin='' id='W5M0MpCehiHzreSzNTczkc9d'?>
        <!-- The serialized RDF goes here. It is removed for brevity. -->
      <?xpacket end='w'?>
    </SCRIPT>
  </head>
  <body>
  </body>
</html>
```

NOTE Adobe has noticed problems with using the SCRIPT element and LANGUAGE attribute in Microsoft Word 2000 running under Microsoft Windows XP: the body content cannot be displayed.

1.5.1.1.2 Using the SCRIPT element and TYPE attribute

```
<html>
  <head>
    <SCRIPT TYPE="text/xml">
      <?xpacket begin='' id='W5M0MpCehiHzreSzNTczkc9d'?>
        <!-- The serialized RDF goes here. It is removed for brevity. -->
      <?xpacket end='w'?>
    </SCRIPT>
  </head>
  <body>
  </body>
</html>
```

1.5.1.1.3 Using the XML element

```
<html>
  <head>
    <XML>
      <?xpacket begin='' id='W5M0MpCehiHzreSzNTczkc9d'?>
        <!-- The serialized RDF goes here. It is removed for brevity. -->
      <?xpacket end='w'?>
    </XML>
  </head>
  <body>
  </body>
</html>
```

1.5.2 XML

XMP metadata, because it is legal XML, can be directly embedded within an XML document. An XMP packet is not intended to be a complete standalone XML document; therefore it contains no XML declaration. The XMP packet can be placed anywhere within the XML document that an element or processing instruction would be legal.

It is recommended that the file be encoded as Unicode using UTF-8 or UTF-16. This provides compatibility for software that scans for XMP packets and parses just their content.

For reference information, see the XML specification: <http://www.w3.org/TR/REC-xml>

1.6 Document formats

- 1.6.1, “PDF”
- 1.6.2, “PS, EPS (PostScript® and Encapsulated PostScript)”

1.6.1 PDF

For PDF files, the XMP packet is embedded in a metadata stream contained in a PDF object (beginning with PDF 1.4). The XMP must be encoded as UTF-8.

This is a partial example of XMP metadata embedded as an XMP packet, stored as a metadata stream:

```
1152 0 obj
<< /Type /Metadata /Subtype /XML /Length 1706 >>
  stream
    <?xpacket begin='' id='W5M0MpCehiHzreSzNTczkc9d'?>
```



```
<!-- The serialized RDF goes here. It has been removed for brevity. -->
<?xpacket end='w'?>
endstream
endobj
```

PDF files that have been incrementally saved can have multiple packets that all look like the “main” XMP metadata. During an incremental save, new data (including XMP packets) is written to the end of the file without removing the old. Top-level PDF dictionaries are also rewritten, so an application that understands PDF can check the dictionary to find only the new packet.

Full documentation on metadata streams in PDF files is available in the *PDF Reference*, Version 1.5: http://www.adobe.com/devnet/pdf/pdf_reference.html

NOTE The PDF specification (not this XMP Specification) is the authority for how XMP is embedded in PDF.

1.6.2 PS, EPS (PostScript® and Encapsulated PostScript)

PostScript is a page description and programming language. Encapsulated PostScript (EPS), is a DSC-conforming PostScript document with additional restrictions intended to make EPS files usable as a graphics file format. EPS files are more-or-less self-contained, reasonably predictable PostScript documents that describe an image or drawing, that can be placed within another PostScript document.

XMP metadata can be placed in PostScript® or EPS files, for use in either PostScript or PDF workflows. This section describes how to place XMP into PostScript or EPS for both the outer document level (main XMP) and for internal objects such as an image (object XMP). It also specifically discusses issues involving Acrobat® Distiller®, since workflows often use Distiller to produce PDF from PostScript and EPS.

NOTE This does not imply that use of Distiller is necessary, or that other application issues do not exist.

There are three important “flavors” of PostScript files that can affect how XMP is written, found, and used. They are:

- DSC PostScript (or just “PostScript”): PostScript conforming to the DSC conventions defined in Appendix G of the PostScript Language Reference.
- Raw PostScript: PostScript following no particular structural conventions. The use of raw PostScript is discouraged. As mentioned in 1.6.2.1.1, “Ordering of content”, a special DSC comment is required to support fast and reliable location of the main XMP.
- EPS: PostScript conforming to the EPS conventions defined in Appendix H of the PostScript Language Reference. EPS is a subset of DSC PostScript.

Because of common usage issues, document-level XMP should be written differently for PostScript and EPS. Object-level XMP is written identically for PostScript and EPS.

The XMP in a PostScript/EPS file must be encoded as UTF-8.

1.6.2.1 Document-level metadata in PostScript

As with any file format, locating contained XMP in PostScript or EPS is most reliably done by fully processing the file format. For PostScript, this means executing the PostScript interpreter. Packet scanning is not reliable whenever a file contains multiple XMP packets, or object XMP without main XMP.

It is often worthwhile to find the main XMP and ignore (at least temporarily) object XMP. Interpretation of the entire PostScript file to locate the main XMP can be very expensive. A hint and careful ordering are used to allow a combination of XMP packet scanning and PostScript comment scanning to reliably find the main XMP.

To write document-level metadata in PostScript, an application must:

- Write the %ADO_ContainsXMP comment as described under 1.6.2.1.1, “Ordering of content”.

- Write the XMP packet as described under [1.6.2.1.2, “Document-level XMP in PostScript”](#).

To write document-level metadata in EPS, an application must:

- Write the %ADO_ContainsXMP comment as described under [1.6.2.1.1, “Ordering of content”](#).
- Write the XMP packet as described under [1.6.2.1.3, “Document-level XMP in EPS”](#).

Use of raw PostScript is discouraged specifically because it lacks the %ADO_ContainsXMP comment. If raw PostScript must be used, the XMP must be embedded as described under [1.6.2.1.2, “Document-level XMP in PostScript”](#).

1.6.2.1.1 Ordering of content

Many large publications use PostScript extensively. It is common to have very large layouts with hundreds or thousands of placed EPS files. Because PostScript is text, locating XMP embedded within PostScript in general requires parsing the entire PostScript program, or at least scanning all of its text. Placed PostScript files can be quite large. They can even represent compound documents, and might contain multiple XMP packets. For PostScript files containing XMP at all, the entire file would have to be searched to make that simple determination.

All of this presents performance challenges for layout programs that want to process XMP embedded in PostScript. As a pragmatic partial solution, a special marker comment can be placed in the PostScript header comments to provide advice about locating the main XMP. This marker must be before the %%EndComments line.

The purpose of this marker is to tell applications consuming the PostScript whether a main XMP is present at all, and how to look for the main XMP. The form of the XMP marker is:

```
%ADO_ContainsXMP: <option> ...
```

The marker must be at the beginning of a line. An option is a contiguous sequence of characters that does not include spaces, tabs, linefeeds, or carriage returns; options are case sensitive. There must be no whitespace before the colon. Applications should ignore options they do not understand.

There are three options defined at present. They are mutually exclusive and provide a hint about how to find the main XMP. Note that the main XMP is not necessarily the document-level XMP:

- **MainFirst:** The main XMP is the first XMP packet in the file and is located near the front of the file. The XMP should be in front of as much PostScript content as possible.
- **MainLast:** The main XMP is the last XMP packet in the file and is located near the back of the file. The XMP should be behind as much PostScript content as possible.
- **NoMain:** There is no main XMP packet for the PostScript file. The file might still contain XMP packets, for example within embedded EPS sections or attached to internal objects.

NOTE 1 The XMP location option applies to both the location of the main XMP in the file and to its position relative to other object-level XMP. The main XMP packet must be before all other XMP if MainFirst is used; it must be after all other XMP if MainLast is used. It is not necessary for the other XMP packets to be adjacent to the main packet.

NOTE 2 When EPS files are concatenated, it is necessary to provide a new set of PostScript header comments for the aggregate, and optionally new a main XMP packet. Otherwise the XMP marker comment from the first EPS portion would erroneously be taken to refer to the aggregate.

1.6.2.1.2 Document-level XMP in PostScript

This section assumes that PostScript devices are level 2 or newer, and that Distiller version 6.0 or newer is used. Compatibility issues are discussed in [1.6.2.1.5, “Compatibility with Distiller 5 for PostScript”](#) and [1.6.2.1.6, “LanguageLevel 1 for PostScript and EPS”](#).

There are three main steps to setting up the document-level XMP:

- 1 Creating a PostScript stream object to contain the XMP.
- 2 Placing the XMP into the stream object.
- 3 Associating the XMP stream object with the document.

XMP metadata must be embedded in a PostScript file in a way that it will be recognized by software that scans files for metadata, which means embedding the complete XMP packet. However, if that file were sent to a PostScript output device, the packet data would cause PostScript errors and the job would fail. To be able to handle arbitrary data, we need a procedure to read the XMP data from the current file, and discard the data if it is not intended to be interpreted.

NOTE In what follows, we define some procedures in a private dictionary, such as:

```
privatedict /metafile_pdfmark {flushfile cleartomark} bind put
```

The name `privatedict` is for illustration purpose only. In the real product code, these procedures should be defined in a unique dictionary so that several EPS files can be used in one document and slightly different versions of these procedures can co-exist.

Here is an example that shows how to embed document-level XMP in PostScript. This example does not include the required marker comment.

```
% =====
% We start with some Postscript prolog. This defines operators and
% procedures that we will use when processing the XMP metadata.
% Define pdfmark to cleartomark, so the data is discarded when consumed
% by a PostScript printer or by Distiller 4.0 or earlier. All following
% references to "privatedict" should be changed to a unique name to
% avoid potential conflicts (see 1.6.2.1.4, "Avoiding name conflicts").
/currentdistillerparams where
{pop currentdistillerparams /CoreDistVersion get 5000 lt} {true} ifelse
{privatedict /pdfmark /cleartomark load put
  privatedict /metafile_pdfmark {flushfile cleartomark} bind put}
{privatedict /metafile_pdfmark {/PUT pdfmark} bind put} ifelse
% =====
% We now create the stream containing the XMP metadata. This must follow
% the prolog shown above, but does not need to be adjacent to it.
% Create a pdfmark named stream object to hold the data. As with the
% privatedict above, use of a unique name is recommended, not literally
% my_metadata_stream_123. The name of this stream is local to the
% Postscript program, it has no outside significance.
% First define the stream object, then read the XMP packet into the
% stream, finally attach the stream as the main XMP.
% The "&&end XMP packet marker&&" comment is significant, it terminates
% the reading of the XMP packet.
% First: Create the XMP metadata stream object and say that it is XMP.
[/_objdef {my_metadata_stream_123} /type /stream /OBJ pdfmark
[ {my_metadata_stream_123} 2 dict begin
  /Type /Metadata def /Subtype /XML def currentdict end /PUT pdfmark
% Second: Fill the stream with the XMP packet.
[ {my_metadata_stream_123}
  currentfile 0 (% &&end XMP packet marker&&)
  /SubFileDecode filter metafile_pdfmark
... XMP packet goes here ...
% &&end XMP packet marker&&
% Third: Attach the stream as the main XMP metadata stream.
[ {Catalog} {my_metadata_stream_123} /Metadata pdfmark
```

1.6.2.1.3 Document-level XMP in EPS

Embedding XMP inside EPS is very similar to PostScript; however, there are issues raised by the common practice of embedding EPS within other EPS or PostScript. The notion of document-level XMP in EPS really means outermost XMP in the EPS. This will be document-level XMP in the PDF if the EPS is distilled alone. This will be appropriate marked content if the EPS is embedded in other EPS or PostScript.

The solution for EPS requires that:

- The XMP must be placed before all EPS content (PostScript drawing commands).
- The `/BDC` and `/EMC` **pdfmarks** must be used to bracket the EPS content.
- The third XMP setup step uses different PostScript code.

Here is an abbreviated example, modified from the previous example:

```
%%EndPageSetup
[/NamespacePush pdfmark
... Do all of the XMP setup as above, up to step 3 ...
% Third: Attach the stream to the Marked Content dictionary.
% All drawing commands must be between the /BDC and /EMC operators.
[/Document 1 dict begin
  /Metadata {my_metadata_stream_123} def currentdict end /BDC pdfmark
[/NamespacePop pdfmark
... All drawing commands go here ...
%%PageTrailer
[/EMC pdfmark
```

1.6.2.1.4 Avoiding name conflicts

In the samples, we used the name `{my_metadata_stream_123}` and suggested that some form of unique name be used. The recommended approach is to generate a typical UUID and strip out all but the significant alphanumeric characters. Use this as a suffix to the name.

An alternate solution is to use `NamespacePush` and `NamespacePop` **pdfmarks**. This is also the recommended solution in the *Pdfmark Reference Manual* (it is accessible from Distiller's Help menu.) This is preferable if possible, but might require large and untenable separation of the push and pop.

It is important to put all **pdfmarks** using the named objects in the same block bracketed by `NamespacePush` and `NamespacePop` pair; for example, the following PostScript code is bad:

```
[/NamespacePush pdfmark
[/_objdef {my_metadata_stream_123} /type /stream /OBJ pdfmark
[{my_metadata_stream_123} 2 dict begin
  /Type /Metadata def /Subtype /XML def currentdict end /PUT pdfmark
[{my_metadata_stream_123}
  currentfile 0 (% &&end XML Packet marker&&)
/SubFileDecode filter metafile_pdfmark
  XML Packet goes here ...
% &&end XML Packet marker&&
[/NamespacePop pdfmark
% At this point, the name {my_metadata_stream_123} is no longer usable.
% next line will cause "undefined" error:
[Catalog] {my_metadata_stream_123} /Metadata pdfmark
```

1.6.2.1.5 Compatibility with Distiller 5 for PostScript

Acrobat Distiller version 5 was the first to include XMP support, but it does not support the `/Metadata pdfmark`. There is no easy way to attach document-level XMP with Distiller 5. It will ignore the `/Metadata pdfmark`, without signaling a PostScript error.

1.6.2.1.6 LanguageLevel 1 for PostScript and EPS

The SubFileDecode filter became available in PostScript LanguageLevel 2. If the PostScript or EPS containing XMP must be processed by PostScript LanguageLevel 1 devices, such as older printers, another approach must be used to read the XMP into the stream object.

With PostScript LanguageLevel 1, there are at least two approaches: using `readstring` to read in the whole XMP packet, or `readline` to read in the XMP packet data line by line until an end marker is found.

We present the `readline` approach here. The `readline` approach solves two problems that exist for `readstring`:

- We do not have to know the exact size of the whole packet, just need to know the maximum length of the lines.
- The exact length of an XMP packet may change if the PostScript/EPS file is re-saved by a text editor with different line ending convention, CR, LF, or CRLF.

Here is an example showing how to use the `readline` approach for PostScript. It is very similar overall to the earlier example, differing only in step 2 and related prolog:

```
% =====
% We start with some Postscript prolog. This defines operators and
% procedures that we will use when processing the XMP metadata.
% Define pdfmark to cleartomark, so the data is discarded when consumed
% by a PostScript printer or by Distiller 4.0 or earlier. All following
% references to "privatedict" should be changed to a unique name to
% avoid potential conflicts. This is discussed later in the section
% "Avoiding Name Conflicts".
/currentdistillerparams where
{pop currentdistillerparams /CoreDistVersion get 5000 lt} {true} ifelse
{privatedict /pdfmark /cleartomark load put} if
% Define another procedure to read line by line from current file until
% marker line is found. The maximum line length is used to create a
% temporary buffer for reading the XMP lines.
% On stack: [ {name} maxLineLength MarkerString
privatedict /metastring_pdfmark
{ 2 dict begin
/markersString exch def string /tmpString exch def
{ currentfile tmpString readline pop
markersString anchorsearch
{pop pop cleartomark exit}
{3 copy /PUT pdfmark pop 2 copy (\n) /PUT pdfmark} ifelse
} loop
end
}bind put
% =====
% We now create the stream containing the XMP metadata. This must follow
% the prolog shown above, but does not need to be adjacent to it.
% Create a pdfmark named stream object in PDF to hold the data. As with
% privatedict above, use of a unique name is recommended, not literally
% my_metadata_stream_123. The name of this stream is local to the
% Postscript program, it has no outside significance.
% First define the stream object, then read the XMP packet into the
% stream, finally attach the stream as the main XMP.
```

```

% The <LineLength> below must be replaced with a value larger than the
% longest line in the XMP packet. There is no safe and general way to
% exactly determine this, the XMP can be modified in place after the
% Postscript is written and could legally all be on one line.
% The overall length of the packet cannot change though. You should set
% the <LineLength> to the lesser of the packet size and 65500. The upper
% limit keeps this within the 64 KB limit of PostScript strings.
% The "&&end XML Packet marker&&" comment is significant, it terminates
% the reading of the XMP packet.
% First: Create the XMP metadata stream object and say that it is XMP.
[/_objdef {my_metadata_stream_123} /type /stream /OBJ pdfmark
[{my_metadata_stream_123} 2 dict begin
  /Type /Metadata def /Subtype /XML def currentdict end /PUT pdfmark
% Second: Read the XMP packet into the stream.
[ {my_metadata_stream_123} <LineLength>
  (% &&end XMP packet marker&&) metastring_pdfmark
... XMP packet goes here ...
% &&end XMP packet marker&&
% Third: Attach the stream as the main XMP metadata stream.
[ {Catalog} {my_metadata_stream_123} /Metadata pdfmark

```

1.6.2.1.7 Traditional PDF metadata and XMP

The discussion here is primarily about explicitly embedding XMP in PostScript and EPS to provide metadata. However, when Distiller is used the document-level metadata in the PDF file can contain information that comes from other sources than the XMP embedded in the PostScript. This is metadata that traditionally went into the PDF document information dictionary, and with the advent of XMP is replicated in the PDF's document-level XMP.

There are two other methods for putting metadata in a PostScript file so Distiller will put it in the PDF document info dictionary and also create and embed an XMP packet for that data in the PDF document. You can use:

- DSC (Document Structuring Conventions) comments. The DSC comments are processed only if DSC parsing is enabled, that is, only if the job file contains the following line:

```
/ParseDSCCommentsForDocInfo true
```

- DOCINFO pdfmark command. Information on pdfmark is available from the Distiller application Help menu, under "pdfmark Guide."

If more than one of the three possible sources of metadata for the PDF file are present, then a property value in the document-level XMP is taken from the first of these sources in the PostScript used to create the PDF that contains the property:

- Explicit document-level XMP.
- Explicit document info dictionary.
- DSC comments.

Because the pdfmark command is more reliable than DSC comments, many applications use it to set DocInfo properties for a PDF document. The following is an example of PostScript code, created by FrameMaker®, which illustrates the use of the DOCINFO pdfmark operator:

```

/Creator (FrameMaker 6.0)
/CreationDate (D:20020214144924)
/ModDate (D:20020215142701)
/Author(John Doe)
/Title (Processing XMP Data in EPS Files)
/Subject (XMP)

```

```
/Keywords (XMP, pdfmark)
/DOCINFO pdfmark
```

Distiller will place these seven properties – plus “Producer” – into the resulting PDF file in two places: the document information dictionary and document-level Metadata as an XML Packet. The Producer is the product name, for example “Acrobat Distiller 5.0 (Windows).” It is possible to add other Key/Value pairs to PDF DocInfo, but they are not added to the document-level Metadata in Distiller 5.0.

Care must be taken if the file might be sent to a PostScript interpreter instead of to Distiller. Some PostScript interpreters may not recognize the pdfmark command, for example those in older printers. One way to avoid problems is to conditionally define the pdfmark operator to the “cleartomark” operator. This is shown in the earlier examples.

1.6.2.2 Object-level metadata in PostScript

Object-level XMP is written identically for PostScript and EPS.

Metadata streams can be attached to specific objects in a PostScript file using the pdfmark operator. This is identical to the document-level PostScript method (see 1.6.2.1.2, “Document-level XMP in PostScript”), except that in step 3 the stream containing the XMP metadata is attached to the object. An example follows showing this for an image:

```
% =====
% We assume that the XMP stream has been defined as shown earlier. All
% but the third step, defining the stream as a metadata stream. We also
% assume that the image has been defined as {myImage_123}. Again, a
% unique name should be used.
% The third step is replaced with one that associates the XMP metadata
% with the image. Since this must be located after both the image and
% XMP streams, it might not be adjacent to the other XMP parts. See the
% ordering issues discussed in “Ordering of Content”.
% Third: Attach the XMP metadata stream to the image.
[ {myImage_123} <</Metadata {my_metadata_stream_123}>> /PUT pdfmark
```

The approach shown here is compatible with all PostScript devices. That is, no additional changes are needed to ensure that level 1 devices will properly ignore the XMP beyond those already mentioned, and Distiller 5 and later will attach the XMP to the associated object in the PDF file.

Although Distiller 5 will attach the XMP to the associated object in the PDF file, the XMP stream in the PDF will be Flate-compressed. This makes the object XMP packet in the PDF invisible to external packet scanners. The XMP will be visible to software processing the PDF format and decompressing the stream. Distiller 6 and later do not compress the XMP packet stream.

1.6.3 UCF (Universal Container Format)

UCF is a general-purpose container technology. As a general container format, UCF collects a related set of files into a single-file container. UCF can be used to collect files in various document and data formats and for classes of applications. The single-file container enables easy transport of, management of, and random access to, the collection.

UCF defines rules for how to represent an abstract collection of files (the “abstract container”) into physical representation within a Zip archive (the “physical container”). The rules for Zip containers build upon and are backward compatible with the Zip technology used by Open Document Format (ODF) 1.0. UCF is designed to provide a set of lightweight constraints on the use of Zip.

The position of XMP within UCF is defined in part 3.5 of the specification:

3.5 META-INF

All valid UCF Containers MAY include a directory called "META-INF" at the root level of the container file system. This directory contains the files specified below that describe the contents, metadata, signatures, encryption, rights and other information about the contained publication.

Specifically, the META-INF/metadata.xml file contains XMP metadata:

3.5.3 Metadata – META-INF/metadata.xml (Optional)

A file with the reserved name "metadata.xml" within the "META-INF" directory at the root level of the container file system may appear in a valid UCF container. This file, if present, MUST be used for container-level metadata. In version 1.0 of OCF, no such container-level metadata is specified.

If the "META-INF/metadata.xml" file exists, its contents MUST be valid XML with namespace-qualified elements to avoid collision with future versions of OCF that MAY specify a particular grammar and namespace for elements and attributes within this file.

Adobe-defined formats based on UCF MUST use XMP to specify metadata.

For further information about UCF, see:

<http://labs.adobe.com/technologies/mars/?tab:details=1#documentation>

2 Handling native metadata

There is a generic policy for how XMP handles native metadata, which covers common practices that should apply to all file formats. However, because application support for XMP long preceded this policy, there are historic and format-specific cases where the generic policy is not followed.

- The mappings for PDF are discussed in 2.2, “Native metadata in PDF files”.
- The individual mappings for dynamic media formats are discussed in 2.3, “Native metadata in dynamic media formats”.
- The common still-image formats (JPEG, TIFF, and PSD) have multiple forms of native metadata; those additional complications are described in 2.4, “Native metadata in digital photography formats”, and complete details are given in 3, “Digital photography native metadata”.

2.1 Reconciling metadata in different formats

Key to all native metadata handling is the notion of reconciling the native metadata with the XMP. Native metadata information can be imported into XMP, and XMP information can be exported to native formats. The generic policy defines when reconciliation happens and how values are transformed. The intent is to preserve the most recent and informative metadata, while allowing the use of both old and new applications.

The basic programming model is described as though the XMP is the only active metadata at runtime:

- When a file is opened, all existing metadata is reconciled into XMP. This does not necessarily mean that data is *imported* to XMP; an import operation only happens if the native metadata appears to be newer than the XMP.
- The XMP is modified as appropriate while the file is open.
- When the file is saved, the relevant XMP is *exported* to native formats, and appropriate forms are written to the file.

The values for all forms stored in the file must be consistent. Existing forms must be updated or removed when a value changes. Which forms are appropriate to write varies with the file format, metadata form, and even specific metadata items. The broadest policy is to write all forms in the interest of maximum compatibility. In some cases there may be mandates that only specific "authoritative" forms be written.

NOTE This is a conceptual programming model meant to aid discussion of the issues of policy. The XMP specification does not require applications that support XMP to follow this specific model.

2.1.1 Text encodings in import and export

It is important to understand text encoding issues before getting into the details of import and export.

The XMP is always written using Unicode, generally UTF-8 although which Unicode does not matter. What does matter is that Unicode is a single text encoding for all languages. The most recent Unicode standard defines over a million characters.

Native metadata often uses more restricted encodings such as 7-bit ASCII, ISO Latin-1, or JIS. In some cases it even uses an ill-defined "local" encoding, the default encoding in effect on a user's machine at any particular moment. There is usually nothing in a file telling what the local encoding was when the file was written, and there is usually no reliable algorithm to determine the local encoding from arbitrary input.

The use of non-Unicode encoding for native metadata means that information can be lost when exporting XMP to native formats. The text encoding used by the native format might not support some of the Unicode characters in the XMP. This typically comes across as question marks in the native format for unsupported characters. Information would be lost from the Unicode if that native format were then imported back to the XMP, downgrading the XMP value.

The XMP metadata can also be corrupted by interactions with locally encoded native metadata. Consider the case of a file saved in Japan using JIS for the local encoding, that is then sent to the US, where Latin-1 is the local encoding. Suppose, for example, that the file is first processed in the US by an application that does not understand XMP and makes the native metadata appear newer than the XMP. If the file is then opened in a XMP-aware application, the native metadata is imported to the XMP. At this time, the JIS values from Japan are interpreted as Latin-1, then converted to Unicode and placed in the XMP. The result is complete garbage (sometimes called “mojibake”) in the XMP, which is then exported back to the native format when the file is saved.

The native-metadata reconciliation policies are designed to minimize these problems.

2.1.2 Native metadata export and import

NOTE The recommended native metadata import and export policy has been modified from that given in earlier versions of the XMP specification. The current policy is inspired by the Metadata Working Group image metadata guidelines.

The choice of metadata reconciliation policy involves several factors and tradeoffs. The goal is to maximize compatibility with a wide variety of software while still being reasonable to implement. One tenet is that XMP-aware software should be smarter and more robust than presumably older XMP-unaware software.

The fundamental requirement for export is that all forms of a metadata item stored in a file must be synchronized. If this is not done then later readers cannot distinguish unsynchronized update from later edits to a subset of forms. This does not mean that values must be fully identical; for example, there can be differences due to text versus binary representation, text formatting, text encoding, native metadata length limitations, and so on. The general policy is to export from the XMP to other forms written to the file, with appropriate conversions as part of the export process. Existing native metadata items must be either updated or deleted when the value changes.

Deciding which forms of a metadata item to write is largely a matter of balancing software compatibility, potential for confusion, and metadata expressiveness. Any time more than one form is written, there is a software burden for reconciliation when reading and synchronization when writing. There may be important older applications that recognize only native metadata. On the other hand, XMP is often more expressive than native formats, providing Unicode values without length limits and data modeling features such as language alternatives.

Two reasonable positions in the metadata form spectrum are:

- Where expressiveness is not an issue and significant native metadata practice is in place, write only the native form as the one and only authoritative form.
- Where expressiveness is an issue, write the native and XMP forms.

When multiple forms might be written, robust readers must locate all forms and select the most appropriate form. This is a concession to the existence of non-compliant writers, software that does not ensure all existing forms are synchronized. The most appropriate form is preferably the most recently written. If this cannot be conveniently determined, then a preference for the native form ensures compatibility with existing XMP-unaware software.

There will generally be a bias in favor of one kind of non-compliant software over others. For example, if the native and XMP values differ, is it because an XMP-unaware application modified the native value, or because an XMP-only application modified the XMP?

Determining when values differ can also be complicated by representation and encoding issues. There might be loss of information when exporting XMP values to a native form. To avoid this, a reader should use the XMP value to predict the native value, then compare that with the actual native value.

2.1.3 Use of native metadata digests

A digest may be used as an optimization to detect change in a native metadata block. This works best when the native metadata is a contiguous block and unlikely to change. Compute the digest when updating a file, after formatting the updated native metadata. Save the digest in the XMP or in some other convenient manner. When opening a file, compute a new digest and compare it to the saved one. If they match, the native metadata is unchanged and can be ignored for reconciliation. If they differ, then something has changed and the per-item reconciliation must be applied. Items that are stored only in a native form must, of course, be imported even if the digest matches.

2.2 Native metadata in PDF files

PDF metadata is stored with a document in the Info dictionary. XMP metadata properties are mapped to defined document Info dictionary keys.

In PDF 1.5, properties are mapped as shown in [Table 19](#):

Table 19 — Mapping of PDF keys to XMP properties

PDF Document Info key	XMP metadata property	Mapping notes
Title	dc:title	The Title key maps to the first of the alternatives given in the dc:title property.
Author	dc:creator	The Author key maps to the first of the creators listed in the dc:creator field. Alternatively (available by user action in the Acrobat 7 UI), maps to a concatenated list of the creators listed in the dc:creator field separated by a standard separator character such as semicolon.
Subject	dc:description	The Subject key maps to the first of the alternatives given in the dc:description property.
Keywords	pdf:Keywords	The XMP properties dc:subject and pdf:Keywords have historically been separate. In Acrobat 7, Adobe allows user intervention to set them to corresponding values, where the value in the PDF schema (and in the DocInfo) is set to a delimiter-separated concatenation of the bag of values found in the dc:subject value.
Creator	xmp:CreatorTool	
Producer	pdf:Producer	
CreationDate ModDate	xmp:CreateDate xmp:ModifyDate	Info dictionary dates are in ISO/IEC 8824 format, XMP dates are in ISO 8601 format.
Trapped	pdf:Trapped	The Trapped key is Boolean.

2.2.1 User-defined keys

In addition to these correspondences, PDF defines an XMP namespace (**pdfx:**) dedicated to representing any user-defined keys present in the Info dictionary. The names of such properties can contain arbitrary Unicode characters; XMP names, however, are constrained to contain only XML Name characters. The following escape convention applies in mapping between the PDF names and the XMP names:

- Characters that are in the Basic Multilingual plane but are not XML Name characters are represented by the character U+2182 (roman numeral ten thousand), followed by four characters from among the

hexadecimal digits; these four characters spell out the Unicode code point of the character being escaped. The hexadecimal digits are case-insensitive; that is any combination of a-f and A-F is allowed.

- Characters having Unicode code points beyond the Basic Multilingual plane have their high, then low, surrogate parts spelled out in this fashion by two consecutive five-character sequences.

2.2.2 Resolving metadata conflicts

If a PDF document contains both an Info dictionary and document-level XMP metadata, it is possible for the representations to get out of synchronization (for example, if Info values are set by software that is unaware of the XMP representation). In order to reconcile such differences, Adobe Acrobat compares the time given by the Info ModDate value with the time given by the xmp:MetadataDate value.

- If the Info value is more recent, all the Info dictionary entries supersede their corresponding XMP properties
- Otherwise, all the XMP values are assumed to be in force.

2.3 Native metadata in dynamic media formats

The following dynamic media formats can contain native metadata which must be reconciled with XMP:

- [Native metadata in ASF \(WMA, WMV\) formats](#)
- [Native metadata in IFF/RIFF \(AVI, WAV, AIFF\) formats](#)
- [Native metadata in MP3](#)
- [Native metadata in digital photography formats](#)

Native metadata in these formats is generally more straightforward than for still image formats; the formats and details of individual properties are both discussed here.

2.3.1 Native metadata in ASF (WMA, WMV) formats

The ASF Header Object contains several nested objects that have native metadata fields mapped to XMP:

Table 20 — Mapping of ASF objects to XMP properties

ASF	XMP
File Properties Object, Creation Date	xmp:CreateDate
This property is ignored, neither imported nor exported, if the Broadcast flag is set. The ASF Creation Date is a UTC time. Recommended policy is to add an appropriate time zone offset in the XMP value, using the local time zone as a default.	
Content Description Object, Title	dc:title['x-default']
Content Description Object, Author	dc:creator[*]
The native value is read as a single string of semicolon separated values, mapped to the dc:creator array in XMP.	
Content Description Object, Copyright	dc:rights['x-default']
Content Description Object, Description	dc:description['x-default']
Content Branding Object, Copyright URL	xmpRights:WebStatement

All native metadata strings are presumed to be little endian UTF-16. The value contains no U+FEFF BOM. Values written to the native format should have a 16-bit NULL terminator. The terminator should be treated as optional when importing to XMP, and stripped if present (not propagated to XMP).

The ASF specification says that the Copyright and License URL values must be ASCII. They should be taken as is when importing to XMP, doing a normal UTF-16 to UTF-8 conversion. When exporting from XMP each byte that is not normal "display" ASCII should be replaced with '?'. The accepted range is 0x21..0x7E.

If an object has to be created to hold a native item, default values (generally 0) should be written for unknown portions of the object.

An MD5 digest of the native metadata is kept in the XMP as `asf:NativeDigest`. The **asf:** namespace URI is "http://ns.adobe.com/asf/1.0/". Only the MD5 digest value should be used for ASF comparisons.

The MD5 digest is computed using the value of the native items, accumulated in the order listed above. The digest is written as an optional series of comma-separated small integers, a semicolon, and a 32-character hexadecimal string for the actual digest value. A leading semicolon is present when the initial small integers are omitted. (The small integers are C enum values indicating the native items actually present when written. They are ignored since this is not in keeping with preferred native-metadata policy.)

2.3.2 Native metadata in IFF/RIFF (AVI, WAV, AIFF) formats

Formats based on IFF include RIFF, on which AVI and WAV are based, and AIFF.

2.3.2.1 Native metadata specific to AVI

AVI files can have four pieces of reconciled native metadata in a LIST/Tdat container chunk:

Table 21 — Mapping of AVI metadata to XMP properties

AVI	XMP
<code>tc_O</code>	<code>xmpDM:startTimecode/xmpDM:timeValue</code>
<code>tc_A</code>	<code>xmpDM:altTimecode/xmpDM:timeValue</code>
<code>rn_O</code>	<code>xmpDM:tapeName</code>
<code>rn_A</code>	<code>xmpDM:altTapeName</code>

Native metadata in a LIST/INFO container chunk is defined by *Multimedia Programming Interface and Data Specifications 1.0*.

This subset of the LIST/INFO container chunk is reconciled with XMP:

Table 22 — Mapping of AVI LIST/INFO to XMP properties

AVI	XMP
<code>IART</code>	<code>xmpDM:artist</code>
<code>ICMT</code>	<code>xmpDM:logComment</code>
<code>ICOP</code>	<code>dc:rights["x-default"]</code>
<code>ICRD</code>	<code>xmp:CreateDate</code>
<code>IENG</code>	<code>xmpDM:engineer</code>
<code>IGNR</code>	<code>xmpDM:genre</code>
<code>INAM</code>	<code>dc:title["x-default"]</code>
<code>ISFT</code>	<code>xmp:CreatorTool</code>

Table 22 — Mapping of AVI LIST/INFO to XMP properties (Continued)

AVI	XMP
IMED	dc:source
ISRF	dc:type

The native values are all written as UTF-8.

There is currently no digest in AVI to detect changes in the native metadata.

2.3.2.2 Native metadata specific to WAV

The WAV format is covered by the base RIFF specification (*Multimedia Programming Interface and Data Specifications 1.0*) and the Exif 2.2 specification, with this exception: WAV files can have a top level DISP chunk, for which there appears to be no public specification. The DISP chunk's content is a 32-bit little-endian integer type code, followed by a null terminated string. The only recognized type code is 1. The top-level DISP chunk is reconciled with **dc:title["x-default"]**.

Metadata in a LIST/INFO container chunk is defined by *Multimedia Programming Interface and Data Specifications 1.0*. This information is also contained in the Exif 2.2 specification, in section 5.6 for "Exif audio files".

Some properties are mapped to the transient namespace "http://ns.adobe.com/riff/info" with the preferred prefix **riffinfo**. These property chunks are imported into XMP for runtime access and updated from XMP. The XMP mappings are not stored in the file.

For WAV files, this subset of the LIST/INFO metadata is reconciled with XMP:

Table 23 — Mapping of WAV LIST/INFO to XMP properties

WAV	XMP
IARL	riffinfo:archivalLocation
IART	xmpDM:artist
ICMS	riffinfo:commissioned
ICMT	xmpDM:logComment
ICOP	dc:rights["x-default"]
ICRD	xmp:CreateDate
IENG	xmpDM:engineer
IGNR	xmpDM:genre
IKEY	dc:subject
IMED	dc:source
INAM	riffinfo:name (language alternative) NOTE Older versions of this specification wrongly mapped INAM to xmpDM:album and later specifications changed the mapping to dc:title . In order to maintain backwards compatibility INAM values should additionally imported to dc:title , but only if there is no previous value for dc:title in the XMP.
IPRD	riffinfo:product

Table 23 — Mapping of WAV LIST/INFO to XMP properties (Continued)

WAV	XMP
ISBJ	dc:description
ISFT	xmp:CreatorTool
ISRC	riffinfo:source
ISRF	dc:type
ITCH	riffinfo:technician

The BEXT chunk, which comes as part of the BWF specification (<http://tech.ebu.ch/docs/tech/tech3285.pdf>) is mapped to XMP using the transient namespace "http://ns.adobe.com/bwf/1.0/". The preferred prefix is "bext". Values are stored only in the BEXT chunk itself, not in the XMP Packet.

The BEXT chunk has a fixed length, so empty properties are written as zeros. This shows the XMP mapping:

Table 24 — Mapping of BEXT chunk properties to XMP

BEXT chunk property	XMP
Description	bext:description
Originator	bext:originator
Originator Reference	bext:originatorReference
OriginationDate	bext:originationDate
OriginationTime	bext:originationTime
TimeReferenceLow	bext:timeReference
TimeReferenceHigh	bext:timeReference (adds to prior field <<32 bit)
Version	bext:version
UMID	bext:umid (encoded as a 128 byte hex string)
CodingHistory	bext:codingHistory

The iXML metadata chunk (<http://www.gallery.co.uk/ixml/>) is also imported to XMP. iXML is an open standard for the inclusion of location sound metadata in Broadcast Wave audio files. iXML uses the XML (eXtensible Markup Language) standard for communication of tagged metadata. All fields are optional when creating an iXML. Some properties are duplicated between the iXML and the BWF Bext chunk. In case of a conflict, BWF bext is given preference.

The XMP Mapping is as follows::

Table 25 — Mapping of iXML chunk properties to XMP

iXML Chunk Property	XMP
<TIMECODE_RATE> <TIMECODE_FLAG>	xmpDM:startTimecode / xmpDM:timeFormat

Table 25 — Mapping of iXML chunk properties to XMP

iXML Chunk Property	XMP
<TIMESTAMP_SAMPLES_SINCE_MIDNIGHT_HI> <TIMESTAMP_SAMPLES_SINCE_MIDNIGHT_LO> <TIMESTAMP_SAMPLE_RATE>	xmpDM:startTimecode / xmpDM:timeValue
<FILE_SAMPLE_RATE>	xmpDM:audioSampleRate
<AUDIO_BIT_DEPTH>	xmpDM:audioSampleType
<TAPE>	xmpDM:tapeName
<SCENE>	xmpDM:scene
<TAKE>	xmpDM:takeNumber
<NOTE>	xmpDM:logComment
<PROJECT>	xmpDM:projectName
<CIRCLED>	xmpDM:good
<BWF_DESCRIPTION>	bext:description
<BWF_ORIGINATOR>	bext:originator
<BWF_ORIGINATOR_REFERENCE>	bext:originatorReference
<BWF_ORIGINATION_DATE>	bext:originationDate
<BWF_ORIGINATION_TIME>	bext:originationTime
<BWF_TIME_REFERENCE_LOW> > <BWF_TIME_REFERENCE_HIGH> >	bext:timeReference
<BWF_VERSION>	bext:version
<BWF_UMID>	bext:umid
<BWF_CODING_HISTORY>	bext:codingHistory

The AES cart chunk is defined in "AES46-2002 (r2007)". The abstract says it is "a convention for communicating basic radio traffic and continuity data via a dedicated chunk embedded in broadcast WAVE file compliant WAVE files.". The specification can be found at <http://www.aes.org/publications/standards/search.cfm?docID=41>

Like BEXT, the cart chunk is imported into XMP for run-time access and updated from XMP. The XMP mappings are not stored in the file. The XMP namespace for the cart chunk is "http://ns.adobe.com/aes/cart" and the preferred prefix is "AEScart".

The XMP properties are simple, all text except one integer. Although the AES cart specification calls for ASCII text, local encoding is used to match the behavior for BEXT. All but one of the text fields have fixed length in the cart chunk. The cart text is null padded as necessary, but may fill the fixed length field with no final null. All of the text fields are imported into the XMP with only local-to-Unicode conversion; there is no other value conversion even for things like date/time values. The XMP text is converted to local encoding when updating

the cart chunk, and then truncated to fit if needed. The XMP text is otherwise exported as-is; the client application is responsible for enforcing any formatting (as in the StartDate "YYYY-MM-DD" format).

The XMP properties are runtime-only. Existing AEScart: properties are deleted when reading, and recreated from a cart chunk if present. The XMP property is not created if the first byte of the cart chunk text field is zero, or missing entirely in the case of the TagText field. The presence of any AEScart: properties causes the cart chunk to be updated when the file is updated. The chunk is created if necessary, then removed from the stored XMP. The written cart chunk has zero bytes for undefined portions, including a single zero byte for the TagText variable length field. An existing cart chunk grows if the output TagText value needs more room.

This shows the XMP mapping of cart properties:

Table 26 — Mapping of cart chunk properties to XMP

Cart properties	XMP
Version	AEScart:Version
Title	AEScart:Title
Artist	AEScart:Artist
CutID	AEScart:CutID
ClientID	AEScart:ClientID
Category	AEScart:Category
Classification	AEScart:Classification
OutCue	AEScart:OutCue
StartDate	AEScart:StartDate
StartTime	AEScart:StartTime
EndDate	AEScart:EndDate
EndTime	AEScart:EndTime
ProducerAppID	AEScart:ProducerAppID
ProducerAppVersion	AEScart:ProducerAppVersion
UserDef	AEScart>UserDef
LevelReference	AEScart:LevelReference
PostTimer	AEScart:PostTimer This is a sorted array of structs. Every array element is a struct of AEScart:Usage (a FOURCC String) and AEScart:Value (an unsigned int32.)
URL	AEScart:URL
TagText	AEScart:TagText

Non-XMP metadata values are all written as UTF-8, and win over XMP values in case of a value mismatch. Older implementations used a 128-bit MD5-formatted digest string to detect changes in some of the non-XMP metadata properties; modern implementations, however, no longer compute or check digests.

2.3.2.3 Native metadata in AIFF

AIFF text chunks are optional and contain metadata information that can be mapped to XMP:

Table 27 — Mapping of AIFF native metadata to XMP properties

AIFF	XMP
NAME	dc:title("x-default")
AUTH	dc:creator[1]
(c)	dc:rights("x-default")
ANNO	xmpDM:logComment (map the first non-empty ANNO chunk)

Native values are all written as UTF-8.

2.3.3 Native metadata in MP3

The ID3v1 tag is always written, regardless of whether it existed previously. If **xmpDM:trackNumber** is set in the XMP data model, it is written as ID3v1.1; otherwise it is written as ID3v1 (see <http://www.id3.org/ID3v1>).

An ID3v1 tag is only imported if an ID3v2 tag (which includes the XMP frame) is not present at all. An ID3v1 tag is assumed to be ASCII. However for interoperability, values above 128 are tolerated and interpreted as Latin-1. On import, the following ID3v1 frames are mapped to XMP:

Table 28 — Mapping of MP3 ID3v1 frames to XMP properties

ID3v1	XMP
title	dc:title["x-default"]
artist	xmpDM:artist
album	xmpDM:album
year	xmp:CreateDate
comment	xmpDM:logComment
genre	xmpDM:genre
track-byte	xmpDM:trackNumber (Reconciled if the second-to-last byte (offset 124) is 0, in accordance with the ID3v1.1 standard)

ID3v2.2, ID3v2.3 and ID3v2.4 tags are all supported. The tag version in an existing MP3 file is not changed. If an ID3 tag must be created, it is version 2.3.

In v2.2, frames are identified by 3-character codes. In later versions, frames are identified by 4-character codes. The following native ID3v2.x frames are mapped to XMP:

Table 29 — Mapping of MP3 ID3v2 frames to XMP properties

ID3v2.2	>ID3v2.2	XMP
COM	COMM	xmpDM:logComment
TAL	TALB	xmpDM:album
TCP	TCMP	xmpDM:partOfCompilation

Table 29 — Mapping of MP3 ID3v2 frames to XMP properties (Continued)

ID3v2.2	>ID3v2.2	XMP
TCM	TCOM	xmpDM:composer
TCO	TCON	xmpDM:genre
TCR	TCOP	dc:rights["x-default"]
TDA, TYE, TIM	TDAT, TYER, TIME,	xmp:CreateDate (for IDV3v2.2 and ID3v2.3)
—	TDRC	xmp:CreateDate (for ID3v2.4)
TT2	TIT2	dc:title["x-default"]
TP1	TPE1	xmpDM:artist
TP4	TPE4	xmpDM:engineer
TPA	TPOS	xmpDM:discNumber
TRK	TRCK	xmpDM:trackNumber
ULT	USLT	xmpDM:lyrics
WCP	WCOP	xmpRights:WebStatement

A known genre should be mapped to XMP as the textual genre name, not the raw number string.

For maximum compatibility, text values in the native metadata frames should be written as true Latin-1 or as little-endian UTF-16 with BOM. For example, some versions of the Windows Media Player ignore the U+FEFF BOM and presume little endian UTF-16.

2.3.4 Native metadata in MPEG-4

MPEG-4 can contain native metadata, which can require reconciliation with the XMP. Metadata can occur in several boxes, as defined by ISO 14496-12:

```
moov/mvhd
moov/udta/cprt
moov/trak/tkhd
moov/trak/udta/cprt
```

An MPEG-4 file must contain exactly one moov box, which must contain exactly one nested mvhd box; the mvhd box provides information about the file as a whole, including creation and modification times, duration, and timescale. The mvhd box is not a container; it is a fixed size record defined in ISO 14496-12 section 8.3.

The moov box can optionally contain at most one udta box, which may optionally contain any number of cprt boxes. A cprt box contains a copyright for the file as a whole. Each has a language code and copyright string.

The moov box also contains one or more trak boxes, each of which contains exactly one tkhd box, optionally at most one udta box, and any number of udta/cprt boxes. These boxes contain similar copyright information for the individual tracks.

Reconciling native metadata with XMP

The XMP is reconciled with native metadata from the moov-level mvhd and udta/cprt boxes. The native values are always imported, taking precedence over the XMP. Individual native items are either always updated when the XMP is updated, or are never updated from the XMP, as noted below in each case.

- The mvhd creation_time and modification_time are mapped to xmp:CreateDate and xmp:ModifyDate

respectively for both import and export. The native values are not imported if the XMP contains the same effective time as the native value but with a UTC offset. The native values are always UTC, which is kept in the XMP if imported.

- The mvhd timescale and duration are always used to compute a value for xmpDM:duration, with enough fractional digits to cover the time scale; for example, a timescale of 60 (1/60th of a second) corresponds to two fractional digits (1/100th of a second) in the XMP. The mvhd timescale and duration are never updated from the XMP.
- The cpri values are mapped to items in the dc:rights array for both import and export. The native values contain an encoded form of an ISO-639-2 language code. XMP uses RFC 3066 codes, which typically include an ISO-639-2 language code plus an ISO 3166 country code.

NOTE Digests are no longer used to decide what is imported or exported, as was the case in previous versions of this specification.

2.4 Native metadata in digital photography formats

Finding and interpreting the metadata embedded in PSD, TIFF, and JPEG files is complicated by the fact that all three file formats contain the same kinds of metadata (XMP, TIFF, Exif, and IPTC), but store it slightly differently.

For example, all of the kinds of metadata can be contained in Photoshop Image Resources (PSIRs), and all three file formats (PSD, TIFF, and JPEG) can contain PSIRs. However, the specific contents of the PSIRs are different when contained in different image file formats. Each type of metadata is stored inside the PSIR for some file formats, and separately for others.

Similarly, TIFF contains both TIFF-specific and Exif metadata, which is stored slightly differently in the TIFF format itself than in the other formats.

This section provides an overview of the storage similarities and differences. The specific details of each native metadata format, and the specific properties that are present in different formats and need to be reconciled, are discussed in 3, “[Digital photography native metadata](#).”

[Figure 5](#) illustrates how metadata is stored in PSD, TIFF, and JPEG files, and what the PSIR section contains in each case.

- In a TIFF file, the arrows in [Figure 5](#) indicate offsets that point to the data; the data itself resides elsewhere in the file.
- A Photoshop image resource (PSIR) actually contains the data pointed to by the arrow in [Figure 5](#).
- In JPEG, the APP n sections also contain the data pointed to by the arrow.

Figure 5 — Metadata in PSD, TIFF, and JPEG files

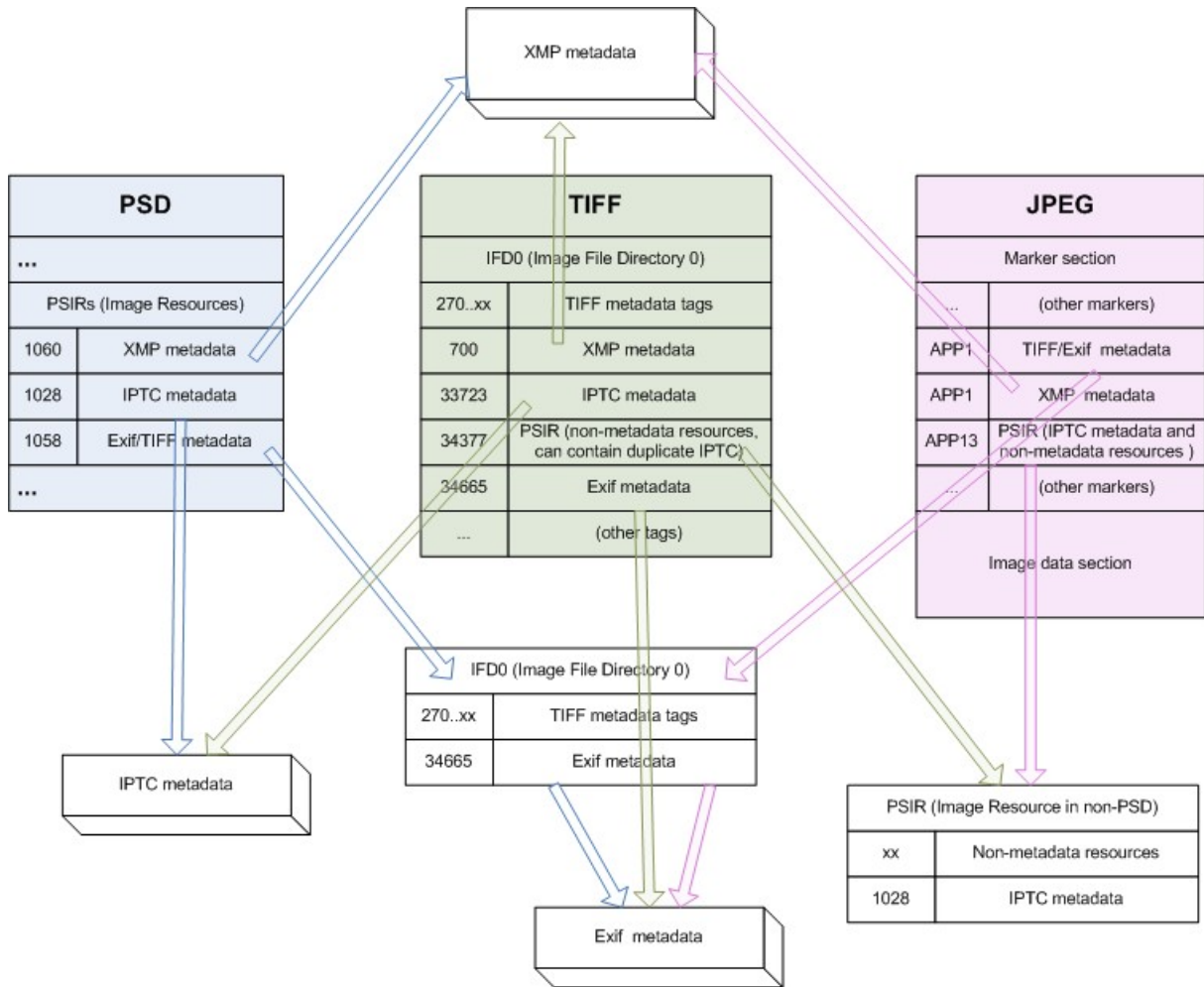

Notice these points:

- A PSD file contains PSIRs, with one image resource for each type of metadata.
 - The resource for Exif/TIFF metadata points to a TIFF IFD0. The IFD contains the TIFF metadata tags and an Exif tag that points to the Exif metadata.
- TIFF, JPEG, and PSIRs all have direct pointers to XMP metadata.
 - The PSIR that appears within TIFF and JPEG does not include an XMP resource, since those formats have direct pointers to the XMP.
- PSD and TIFF point directly to the IPTC metadata, but JPEG contains a PSIR that contains the IPTC.
 - TIFF also contains a PSIR, which might contain a duplicate of the IPTC that is pointed to directly by its own tag.
- TIFF contains a tag that points directly to the Exif metadata; however, JPEG (like PSD) has a marker that points to a TIFF IFD0. The IFD contains the TIFF metadata tags and an Exif tag that points to the Exif metadata.

2.4.1 Reconciliation issues

This section clarifies specific issues of reconciling native metadata with XMP for digital photography formats.

The important aspects of reconciliation among TIFF/Exif, IPTC, and XMP metadata in digital photography formats are well covered in the Metadata Working Group's still-image metadata guidelines.

Earlier versions of the XMP specification recommended keeping copies of TIFF and Exif technical metadata in the XMP stored in a file. These are XMP properties in the tiff: and exif: namespaces. In keeping with the Metadata Working Group guidelines, only the native TIFF and Exif tags should be stored for these items.

In general, properties in the tiff: and exif: namespaces should be ignored for JPEG, TIFF, and PSD files if the corresponding native tag exists. An exception is **exif:ISOSpeedRating**, when the native tag has a value of 65535. The Exif tag has a 16-bit unsigned type, but recent cameras support ISO values above 65535. Some applications extract the actual ISO value from the proprietary MakerNote tag and store it in the XMP property **exif:ISOSpeedRating**.

2.4.2 Encoding of text in metadata

The encoding of text strings varies among the metadata formats, and Adobe practice does not always precisely follow the relevant specifications. The only easy case is XMP, which always uses Unicode; specifically UTF-8 for PSD, TIFF, JPEG, JPEG-2000, GIF, PNG, DNG, and camera raw files.

The Mac OS STR# and TEXT file resources use local OS single-byte encoding, with no indication in the file of what that is.

Photoshop image resources have one active and two obsolete standalone strings. These all use local OS single-byte encoding, with no indication in the file of what that is. The active string is image resource 1035, copyright information URL. The obsolete strings are 1008, old caption, and 1020, old print caption.

The major native standards specify 7-bit ASCII for the most part:

Table 30 — Encoding of text strings in metadata

TIFF/ Exif	All but 3 string values have type ASCII, which means 7-bit ASCII. The remaining 3 have directly indicated encoding: <ul style="list-style-type: none">• UserComment (37510)• GPSProcessingMethod (27)• GPSAreaInformation (28).
IPTC	All values are written as ISO 646, which is 7-bit ASCII with national variants.

Photoshop takes liberties with the interpretation of ASCII and ISO 646. Through version 7, it uses local OS single-byte (8-bit) encoding where TIFF/Exif and IPTC specify 7-bit ASCII or ISO 646. There is no indication in the file of what this encoding is. Photoshop 9 continues to use local OS single-byte (8-bit) encoding for IPTC, but uses UTF-8 in TIFF/Exif for tags of type ASCII.

Photoshop also ignores the Exif admonition to use the UserComment tag instead of ImageDescription when the value contains non-ASCII characters. Photoshop always writes ImageDescription, never UserComment.

3 Digital photography native metadata

This chapter discusses how native metadata is stored in the various still-image formats (3.1, “[Metadata storage in native formats](#)”), and provides details of the properties that are equivalent in different formats, and how they are mapped to XMP (3.2, “[Reconciling metadata properties](#)”).

3.1 Metadata storage in native formats

This section provides details of the native metadata formats used in the common digital photography formats (PSD, JPEG, and TIFF). Each of these file formats can contain metadata in any of the following formats, in addition to XMP:

- 3.1.1, “[TIFF metadata](#)”
- 3.1.2, “[Exif metadata](#)”
- 3.1.3, “[Photoshop image resources](#)”
- 3.1.4, “[IPTC \(IIM\) metadata](#)”

For details of the specific properties that need to be reconciled among metadata formats, see 3.2, “[Reconciling metadata properties](#)”.

3.1.1 TIFF metadata

Modification of TIFF files must be done with care to preserve the linked structure. The Exif and GPS IFD pointers (see 3.1.2, “[Exif metadata](#)”) illustrate the potential problem of detecting implicit links. These tags have type LONG and a count of 1, the fact that they are links is not explicit. Nothing prevents new versions of Exif from adding similar IFD pointers, or applications from adding similar private tags. Updates to TIFF files should be done in one of these ways:

- Rewrite the entire file, output only those tags that are explicitly understood.
- Use an update by append approach. Append all new or resized IFDs and values to the end of the file and adjust known offsets to them.
- The TIFF specification does not allow tags to be repeated in an IFD. You should write tags in order, with no duplicates. A robust TIFF reader, however, should tolerate tags that are out of order. If duplicates do occur, Adobe practice is to keep the last encountered tag.

For information on specific metadata tags, see 3.2.3, “[TIFF and Exif tags for metadata](#)”.

3.1.2 Exif metadata

The Exif image interchange format defines a set of TIFF tags that describe photographic images, and is widely used by digital cameras. Exif metadata is found in TIFF, JPEG, and PSD files.

According to Exif conventions, the first IFD (IFD0) describes the primary image, the next IFD (IFD1) describes thumbnails. It allows either uncompressed images based upon TIFF, or compressed images based upon JPEG. In fact, the IFDs may or may not contain image data, depending on whether they are in a TIFF or a JPEG file.

The additional information defined by Exif is located through these TIFF tags, regardless of the surrounding file format:

Table 30 — Additional Exif data

Tag	Hex	Name	
34665	0x8769	Exif IFD pointer	<ul style="list-style-type: none"> In a TIFF file, IFD0 contains tags of this type, which point to subsidiary IFDs that contain tags that point to the data blocks. In PSD files, an image resource contains these IFDs, which point directly to the data. The data is contained within the PSIR. In JPEG files, an APP1marker contains these IFDs, which point directly to the data. The data is contained within the marker.
34853	0x8825	GPS IFD pointer	

NOTE Even though JPEG is a big-endian format overall, the TIFF within the Exif APP1 marker segment can be little-endian. Readers must recognize and honor the 8-byte TIFF header.

For information on specific metadata tags, see 3.2.3, “TIFF and Exif tags for metadata”.

The Exif specification is owned by the Japanese Camera & Imaging Products Association (CIPA). The Exif 2.3 specification can be found at http://www.cipa.jp/std/documents/e/DC-008-2012_E.pdf

3.1.3 Photoshop image resources

Photoshop image resources are used in PSD, TIFF, and JPEG files. The contents differ in the different contexts:

- The image resource section is a native part of the PSD file format, and consists of a 4-byte length value, followed by a sequence of image resources, which include both non-metadata resources and all of the metadata (XMP, TIFF/Exif, and IPTC).
- JPEG and TIFF file formats contain just the sequence of image resources; the overall length is part of the containing file structure.
 - In TIFF, the resource pointer is TIFF tag 34377 (0x8649). It points to sequence of image resources that contain non-metadata resource data, and can contain duplicate IPTC metadata (which also has its own TIFF tag). The image resources do not contain XMP or TIFF/Exif metadata, which have their own TIFF tags.
 - In JPEG, the resource is contained in an APP13 marker segment with a signature string of "Photoshop 3.0". It contains a sequence of image resources that contain non-metadata resources and IPTC metadata. The image resources do not contain XMP or TIFF/Exif metadata, which have their own markers.

Each Photoshop image resource has the following form:

Table 31 — Format of Photoshop image resources

Offset	Length	Description
0	4	Resource type, the 4 ASCII characters "8BIM" for the resources described here.
4	2	Resource ID, a 16-bit big-endian unsigned integer.
6	—	Resource name as a Pascal string.
—	4	Length of the resource data, a 32-bit big-endian unsigned integer
—	—	Resource data

The image resources need not be sorted in any way. The resource name and data are followed as necessary by a 0x00 pad byte to make the total length be even; that is, to make the following component begin on an even offset. The explicit length of the name or resource data does not include this pad.

This padding is relative to the image resource section, not necessarily to the overall file. For example, the image resources in a JPEG file might begin on an odd file offset because JPEG allows marker segments to begin on any offset. Readers and writers must use care to round local image resource relative offsets, not base file relative offsets.

The image resource ID and data length must always be written as big-endian, even when the image resources are embedded within little-endian TIFF.

For information on specific metadata properties in image resources, see [3.2.1, “Photoshop image resources for metadata”](#).

3.1.4 IPTC (IIM) metadata

The International Press Telecommunications Council (IPTC) and NAA (Newspaper Association of America) have together defined the Information Interchange Model (IIM) that has come to be known as “IPTC metadata.”

IPTC metadata is stored as a sequence of DataSets. The DataSets are logically grouped into Records. A DataSet is referenced as *record:dataset*; for example, DataSet 2:50 is DataSet 50 of Record 2. DataSets can be stored in a standard or extended form.

The structure of a standard DataSet is shown in [Table 32](#):

Table 32 — Standard data set structure

Offset	Length	Description
0	1	Tag marker, 0x1C
1	1	Record number
2	1	DataSet number
3	2	Data length, big-endian, range 0..32767
5	—	Data

The structure of an extended DataSet is shown in [Table 33](#):

Table 33 — Extended data set structure

Offset	Length	Description
0	1	Tag marker, 0x1C
1	1	Record number
2	1	DataSet number
3	2	“Data length” length, the number of bytes in the variable-length “Data length” portion at offset 5. Big-endian, ORed with 0x8000
5	—	Data length, the number of bytes in the Data portion following. Big-endian, variable length as specified in preceding length value.
—	—	Data

The DataSets must be clustered by Record number, and the clusters written in ascending Record order. The DataSets within a Record cluster may be in any order.

The 16-bit data length field is always stored big-endian, on all platforms, even when the IPTC is placed within little-endian TIFF.

For information on specific metadata properties in DataSets, see 3.2.2, “IPTC DataSets for metadata”.

The IIM specification can be found at: <http://www.iptc.org/IIM/>

The more recent IPTC specification for metadata that is only in XMP, and not in the IIM structure, has no reconciliation issues and is not relevant to this discussion.

3.2 Reconciling metadata properties

This section provides details about individual native metadata properties in native formats and how they are mapped to XMP.

- 3.2.1, “Photoshop image resources for metadata”
- 3.2.2, “IPTC DataSets for metadata”
- 3.2.3, “TIFF and Exif tags for metadata”

Collections of metadata (for example, XMP or IPTC) are mentioned only where they are intermingled with individual properties. For example, the first table below shows this intermingling of individual properties in Photoshop image resources 1034 and 1035, and collections in 1028, 1058, and 1060.

3.2.1 Photoshop image resources for metadata

There are several Photoshop image resources of interest as metadata:

Table 34 — Photoshop image resources useful as XMP metadata

ID	Hex	Description	XMP mapping	Notes
1028	0x404	IPTC metadata		
1034	0x40A	Copyright flag as a 0/1 Boolean	xmpRights:Marked	When importing, set the XMP to "True" if 1034 has length 1 and a non-zero value, otherwise leave the XMP alone. When exporting, set 1034 to 0/1 if the XMP is present and True/False, else do not set 1034.
1035	0x40B	Text string for a copyright information URL	xmpRights:WebStatement	The image resource is treated as locally encoded text.
1058	0x422	Standard Exif (added in Photoshop 7)		In the standard TIFF format, including the initial 8 byte header. Even though Photoshop is a big-endian format overall, the TIFF within image resource 1058 can be little-endian. Readers must recognize and honor the 8 byte TIFF header.

Table 34 — Photoshop image resources useful as XMP metadata (Continued)

1060	0x424	XMP (added in Photoshop 7)		
1061	0x425	MD5 digest of the IPTC (added in Photoshop 7)		The 16-byte binary value is the MD5 digest of the contents of PSIR 1028.

Some very old versions of Photoshop wrote image resource 1008 (0x3F0) or 1020 (0x3FC), but not both. These are now considered obsolete; both were dropped prior to Photoshop 6. The current Photoshop SDK does not even contain type information for 1020. Both of these are captions, rendered as Pascal strings; they are alternative forms corresponding to the IPTC Caption in DataSet 2:120. They are never exported to XMP.

When the size of the PSIR block exceeds 64KB, Photoshop splits the block into multiple APP13 markers of 64KB each and then embeds the blocks into the JPEG. In such cases, while the PSIR data is imported into XMP after merging, all these individual APP13 markers to form the complete block. The individual APP13 markers are assumed to be in the original order.

3.2.2 IPTC DataSets for metadata

Unless otherwise noted, the data in all DataSets of interest as metadata are graphic characters plus spaces from ISO 646. Which is essentially 7-bit ASCII overlain with a variety of national variants. These variants are all still within the 7-bit range. The national variant in use at any time is not specified and not detectable from the data. Graphic characters are in the range 0x21..0x7F, space (0x20) is not considered a graphic character (hence the “plus spaces” above). Alphabetic characters are the English alphabet in ASCII, A..Z (0x41..0x5A) and a..z (0x61..0x7A).

Unless otherwise noted, a given DataSet of interest as metadata can appear at most once. DataSets that can be repeated are marked in the following table with an X in the Repeat column. Those that can be repeated need not be contiguous.

A robust reader should tolerate improper repeats in input. Adobe practice depends on the mapping to XMP:

- A nonrepeatable DataSet is always mapped to a simple XMP property; if there is an improper repeat, the last value encountered is kept.
- For a repeatable DataSet that is mapped to a simple XMP property, the last value encountered is kept. The XMP mappings for the repeatable DataSets 2:85 (**photoshop:AuthorsPosition**) and 2:122 (**photoshop:CaptionWriter**) are simple XMP properties, not arrays.
 - The DataSet 2:80 is repeatable, but is mapped to only the first item in the **dc:creator** array. It is treated as if it were mapped to a simple property. On import, only the last value is kept. On export from XMP, only the first item in the XMP **dc:creator** array is output as a 2:80 DataSet.
- For a repeatable DataSet that is mapped to an XMP array, all repeated values are both imported and exported as separate array items. An example is DataSet 2:25 (**dc:subject** array).

It is also Adobe practice to keep all of a value when importing to XMP, even if the value is larger than allowed (as shown in the following table). When exporting from XMP, large values are truncated to the allowed size.

The IPTC DataSets of interest as metadata are shown in [Table 35](#):

Table 35 — IPTC data sets of use as XMP metadata

ID	Hex	Name	Repeat	Description
2:5	0x0205	Object Name		(title), maximum 64 bytes
2:10	0x020A	Urgency		one ASCII digit, '1'..'8'

Table 35 — IPTC data sets of use as XMP metadata (Continued)

2:15	0x020F	Category		alphabetic characters, maximum 3 bytes
2:20	0x0214	Supplemental Category	R	maximum 32 bytes each
2:25	0x0219	Keywords	R	maximum 64 bytes each
2:40	0x0228	Special Instructions		maximum 256 bytes
2:55	0x0237	Date Created		8 ASCII digits as CCYYMMDD, 00 for unknown parts
2:60	0x023C	Time Created		11 ASCII characters in the format HHMMSS±HHMM, following ISO 8601
2:62	0x023E	Digital Creation Date		8 ASCII digits as CCYYMMDD, 00 for unknown parts
2:63	0x0240	Digital Creation Time		11 ASCII characters in the format HHMMSS±HHMM, following ISO 8601
2:80	0x0250	By-line	R	maximum 32 bytes each
2:85	0x0255	By-line Title	R	maximum 32 bytes each
2:90	0x025A	City		maximum 32 bytes
2:95	0x025F	Province/State		maximum 32 bytes
2:101	0x0265	Country/Primary Location Name		maximum 64 bytes
2:103	0x0267	Original Transmission Reference		maximum 32 bytes
2:105	0x0269	Headline		maximum 256 bytes
2:110	0x026E	Credit		maximum 32 bytes
2:115	0x0273	Source		maximum 32 bytes
2:116	0x0274	Copyright Notice		maximum 128 bytes
2:120	0x0278	Caption		graphic characters, spaces, CR, LF, maximum 2000 bytes
2:122	0x027A	Writer	R	maximum 32 bytes each

The IPTC DataSet mappings to XMP are shown below. The namespace URIs and other details are in the *XMP Specification Part 2, Additional Properties*. The notation `ns:array["x-default"]` means the item in the `ns:array` language alternative whose `xml:lang` qualifier has the value "x-default".

Table 36 — Mapping of IPTC data set items to XMP properties

ID	XMP mapping
2:4	<code>iptc4xmpCore:IntellectualGenre</code>
2:5	<code>dc:title["x-default"]</code>
2:10	<code>photoshop:Urgency</code> (incorrectly given as 2:9 in the IPTC Core 1.0 specification)
2:12	<code>iptc4xmpCore:SubjectCode</code>

Table 36 — Mapping of IPTC data set items to XMP properties (Continued)

2:15	photoshop:Category
2:20	photoshop:SupplementalCategories (gathered as an unordered array)
2:25	dc:subject (gathered as an unordered array)
2:40	photoshop:Instructions
2:55, 2:60	photoshop:DateCreated Reformatted as ISO 8601, which has both a date and a time; 2:55 is just a date; 2:60 is included for the time portion, if present.
2:62, 2:63	xmp:CreateDate Reformatted as ISO 8601, which has both a date and a time; 2:62 is just a date; 2:63 is included for the time portion, if present.
2:80	dc:creator (gathered as an ordered array)
2:85	photoshop:AuthorsPosition
2:90	photoshop:City
2:92	iptc4xmpCore:Location
2:95	photoshop:State
2:100	iptc4xmpCore:CountryCode
2:101	photoshop:Country
2:103	photoshop:TransmissionReference
2:105	photoshop:Headline
2:110	photoshop:Credit
2:115	photoshop:Source
2:116	dc:rights["x-default"]
2:120	dc:description["x-default"]
2:122	photoshop:CaptionWriter

3.2.3 TIFF and Exif tags for metadata

The IFDs used in TIFF and Exif can contain a large number of tags that are of interest as metadata. All but 5 of these tags are for individual metadata properties. The other 5 are for subsidiary IFDs or blocks of metadata in another format; these 5 tags must appear in the TIFF first (0th) IFD:

Table 37 — IFD tags

Tag	Hex	Usage
700	0x2BC	XMP
33723	0x83BB	IPTC DataSets
34377	0x8649	Photoshop image resources
34665	0x8769	Exif IFD offset

Table 37 — IFD tags (Continued)

34853	0x8825	GPS IFD offset
-------	--------	----------------

3.2.3.1 Text encoding and tags with substructure

Although many Exif tags are of type ASCII and formally restricted to 7-bit ASCII characters, Adobe practice is to use UTF-8 for all TIFF and Exif tags of type ASCII. This allows all characters to be preserved directly between the tag and XMP forms.

There are 2 tags that have substructure, Artist and Copyright. The tag details are in the Exif specification.

- For the Artist tag, Exif recommends that multiple names be separated with semicolons; the example given in the specification are "Camera owner, John Smith; Photographer, Michael Brown; Photographer, Michael Brown". The XMP mapping is to **dc:creator**, which is an array. The XMP value should separate names at the semicolon. The example should result in a 3-item **dc:creator** array: "Camera owner, John Smith", "Photographer, Michael Brown", and "Photographer, Michael Brown". When moving XMP to Exif, concatenate the items using semicolons to create the Artist value.
- For the Copyright tag, Exif recommends individual photographer and editor copyrights, separated by an internal NULL byte. When moving from the tag to XMP, convert any internal NULLs to linefeeds (U+000A). Do no conversion when moving from XMP to the tag.

Most TIFF and Exif tags with text values are of type ASCII. A few have an UNDEFINED physical type, but actually contain generally well defined text with flexible encoding. The value includes a header defining the encoding of the subsequent text. These tags are shown in [Table 38](#):

Table 38 — TIFF and Exif tags with undefined physical types

37510	UserComment
27	GPSProcessingMethod
28	GPSAreaInformation

The encoding header is the first 8 bytes of the tag value, an ASCII string will NULL padding. The remainder of the tag value is the encoded text, without NULL termination. (And thus without the concept of multiple internal strings that ASCII tags have.) The encodings are shown in [Table 39](#):

Table 39 — TIFF and Exif encoding headers

"ASCII\0\0\0"	ISO 646, in essence 7-bit ASCII with national variants
"JIS\0\0\0\0\0"	JIS X208-1990
"UNICODE\0"	UTF-16 Unicode
"\0\0\0\0\0\0\0\0"	Undefined, implication of local OS encoding

The Exif specification does not mention whether the UTF-16 form should be big or little-endian. A reasonable presumption is to follow the ordering given in the TIFF header. The Exif specification says that UserComment should be used instead of ImageDescription for non-ASCII text. The XMP mapping uses only ImageDescription; because of the recommendation to use UTF-8, there is no loss of information, and no benefit to using UserComment.

3.2.3.2 Writeback tags

Most of the TIFF, Exif, and GPS tags that are mapped to XMP are considered read-only in the XMP. Edits to the XMP value should not be allowed, modified XMP values should not be written back to the native tags. The only writeback tags are shown in [Table 40](#):

Table 40 — TIFF, Exif, and GPS writeback tags

270	TIFF ImageDescription
274	TIFF Orientation
282	TIFF XResolution
283	TIFF YResolution
296	TIFF ResolutionUnit
305	TIFF Software
306	TIFF DateTime
315	TIFF Artist
33432	TIFF Copyright
37510	Exif UserComment
40964	Exif RelatedSoundFile

3.2.3.3 Value conversions for TIFF and Exif tag values

The value conversions for TIFF and Exif tags are mostly straightforward. Integer values are converted to decimal strings in the manner of "%d" in C printf. Rational numbers are converted to a *numerator/denominator* form; for example, the pair (123,456) becomes "123/456". Signed rationals are normalized to have only a leading minus, if any. The pair (123,-456) becomes "-123/456" and (-123/-456) becomes "123/456".

Tags of type ASCII are converted allowing for UTF-8 or local encoding. If a native string contains a valid UTF-8 sequence it is imported to XMP as-is. Otherwise, a local to UTF-8 conversion is performed. It is possible for a locally encoded value to look like UTF-8 and be erroneously imported as UTF-8, but this is very unlikely.

A date/time value is converted to ISO 8601 notation. The Exif date/time part is a 20-byte ASCII value formatted as "YYYY:MM:DD HH:MM:SS" with a terminating null. Any of the numeric portions can be blank if unknown. The fractional seconds are a null-terminated ASCII string with possible space padding. They are literally the fractional part, the digits that would be to the right of the decimal point.

The Exif date/time does not have a timezone component. Although strict ISO 8601 requires timezone information, it is optional in XMP usage. Applications must not arbitrarily add timezone values to imported Exif values.

GPS latitude and longitude values are combined with their "ref" part to produce a single XMP map coordinate.

- The native numeric portion is 3 rational numbers for degrees, minutes, and seconds. If all 3 denominators are 1, the numeric portion of the XMP is "deg,min,sec". Otherwise, floating-point arithmetic is used to normalize the coordinate to "deg,min.frac", with enough fractional minute digits to cover the largest of the 3 denominators.
- The ref portion in the native format is an ASCII letter for the English compass directions ('N', 'S', 'E', 'W') and is appended directly to the numeric portion in the XMP value. Assuming a ref of 'N', for example, the native format (12/1,34/1,56/1) becomes "12,34,56N" in XMP. The native format (12/1,34/1,56789/1000) becomes "12,34.946N".

3.2.3.4 TIFF and Exif digests

Prior versions of the XMP specification recommended the use of digests to detect changes to the TIFF and Exif tags. This policy has been dropped in compliance with Metadata Working Group image metadata guidelines. Existing TIFF and Exif digests found in the XMP (tiff:NativeDigest and exif:NativeDigest) should be ignored when reading and removed when updating.

3.3 Metadata storage

The intersection of file formats and metadata forms has confusing inversions, with portions of metadata being wrapped and stored in a variety of ways in the file formats. For example, a TIFF file contains a block of Photoshop image resources as the value of a TIFF tag, while a Photoshop file contains a TIFF header plus IFDs as the value of an image resource. This section will outline metadata storage organized by file type and by metadata type.

3.3.1 Storage by metadata form

TIFF tags for individual properties, including TIFF/Exif, can be found in locations shown in [Table 41](#):

Table 41 — TIFF tags for individual properties

File format	Storage location
Photoshop	TIFF within image resource 1058
TIFF	Native IFDs
JPEG	TIFF within Exif APP1 marker segment

NOTE Photoshop 6 split the tags in a TIFF file between proper native tags and “buried” tags in image resource 1058 within tag 34377. See [3.3.4.1, “Photoshop 6 and TIFF”](#).

Photoshop image resources for individual properties can be found in the locations shown in [Table 42](#):

Table 42 — Photoshop image resource locations

File format	Storage location
Photoshop	Native image resource section
TIFF	Tag 34377 in the 0th IFD
JPEG	Photoshop APP13 marker segment

IPTC DataSets can be found in the locations shown in [Table 43](#):

Table 43 — IPTC dataset locations

File format	Storage location
Photoshop	Photoshop image resource 1028
TIFF	Tag 33723 in the 0th IFD; Photoshop image resource 1028
JPEG	Photoshop image resource 1028
Any Mac	Mac OS file resource 'ANPA' 10000 (prior to Photoshop 9)

XMP can be found in the locations shown in [Table 44](#):

Table 44 — XMP locations

File format	Storage location
Photoshop	Photoshop image resource 1060
TIFF	TIFF tag 700
JPEG	XMP APP1 marker segment

Additionally, keywords and description can be found in Mac OS file resources:

Table 45 — Mac OS file resources

File format	Storage location
Any Mac OS	Mac OS file resources from 'pnot' 0 items KeyW and Desc

Reading and writing of the Mac OS ANPA 10000 resource and the pnot 0 resource's KeyW and Desc items was dropped in Photoshop 9.

3.3.2 Metadata storage in JPEG files

JPEG files, including Exif JPEG, use a mixture of native marker segments, TIFF tags, and Photoshop image resources. Metadata can be found in 3 APPn marker segments:

Table 46 — APPn marker segments containing XMP metadata

Marker	Signature, including NULLs	Usage
APP1	"Exif\0\0"	TIFF and Exif (2 NULLs)
APP1	"http://ns.adobe.com/xap/1.0\0"	XMP
APP13	"Photoshop 3.0\0"	Photoshop image resources

The TIFF in the Exif APP1 marker segment should not contain tag 700 (XMP), tag 33723 (IPTC), or tag 34377 (Photoshop image resources). There should be only one copy of the IPTC in a JPEG file, in Photoshop image resource 1028 (ignoring the possible Mac OS ANPA 10000 resource).

The Photoshop image resources for metadata that can be used in JPEG are shown in [Table 47](#). Other non-metadata image resources might also be present. Image resources 1058 (TIFF) and 1060 (XMP) should not be used in JPEG files.

Table 47 — Photoshop resources that can be used in JPEG

ID	Hex	Description
1028	0x404	IPTC DataSets
1034	0x40A	Copyright flag as a 0/1 Boolean
1035	0x40B	Text string for a copyright information URL
1061	0x425	MD5 digest of the IPTC data

3.3.3 Metadata storage in Photoshop files

Photoshop files use Photoshop image resources as the metadata storage mechanism. The metadata image resources were listed earlier, and are repeated in [Table 48](#). Other non-metadata image resources might also be present.

Table 48 — Photoshop image resources

ID	Hex	Description
1028	0x404	IPTC DataSets
1034	0x40A	Copyright flag as a 0/1 Boolean
1035	0x40B	Text string for a copyright information URL
1058	0x422	Exif metadata
1060	0x424	XMP
1061	0x425	MD5 digest of the IPTC DataSets

The TIFF in image resource 1058 can contain a full set of the TIFF metadata tags for individual properties, including use of the Exif and GPS subsidiary IFDs. The TIFF in a Photoshop file should not contain XMP or IPTC (TIFF tags 700 or 33723) or nested copies of image resources (TIFF tag 34377).

Some very old versions of Photoshop wrote image resource 1008 or 1020, but not both. These are now considered obsolete and both were dropped prior to Photoshop 6. The current Photoshop SDK does not contain type information for 1020.

Table 49 — Obsolete Photoshop image resources

ID	Hex	Description
1008	0x3F0	Caption as a Pascal string
1020	0x3FC	Caption as a plain string

3.3.4 Metadata storage in TIFF files

As mentioned earlier, the IFDs used in TIFF and Exif contain a large number of tags that are of interest as metadata. All but five of these tags are for individual metadata properties. The other five are for contained blocks of metadata:

Table 50 — TIFF and Exif tags for contained metadata blocks

Tag	Hex	Usage
700	0x2BC	XMP
33723	0x83BB	IPTC DataSets
34377	0x8649	Photoshop image resources
34665	0x8769	Exif IFD offset
34853	0x8825	GPS IFD offset

The TIFF physical type (BYTE, SHORT, LONG, etc.) must be taken into account when processing the XMP, IPTC, and image resources. There may be appended 0x00 bytes to make the total size be a multiple of the

physical unit. Software loops processing the data must be prepared to terminate 1 to 3 bytes early, depending on the physical unit.

The Photoshop image resources for metadata that can be used in TIFF are shown in [Table 51](#). A TIFF file should not contain image resource 1060 (XMP). A TIFF file might contain image resource 1058 (TIFF) because of the Photoshop 6 feature/bug mentioned below. Other non-metadata image resources might also be present.

Table 51 — Photoshop resources that can be used in TIFF

ID	Hex	Description
1028	0x404	IPTC DataSets
1034	0x40A	A Copyright flag as a 0/1 Boolean
1035	0x40B	Text string for a copyright information URL
1061	0x425	MD5 digest of the IPTC DataSets

NOTE TIFF files contain 2 copies of the IPTC: in the top level TIFF tag 33723, and in image resource 1028 within TIFF tag 34377. Photoshop 6, Photoshop 7, and Photoshop 9 all do this. There is also a possible third copy of the IPTC in the Mac OS ANPA 10000 resource.

3.3.4.1 Photoshop 6 and TIFF

Photoshop 6 wrote TIFF in an awkward and nonintuitive manner. Photoshop 6 placed most of the TIFF/Exif information within image resource 1058 instead of natively in the "real" TIFF file IFDs. This includes the Exif subsidiary IFD, tag 34665 is only written in the 0th IFD within image resource 1058. In addition, tags 259, 270, 282, and 296 were written in both the outer native 0th IFD and in the 0th IFD within image resource 1058. Several tags are also duplicated between the 0th and 1st IFDs image resource 1058. But since that is duplication between the main image and thumbnail and the 1st IFD contains a proper subset of the tags in the 0th IFD, those in the 1st IFD can be ignored.

Photoshop 7 and Photoshop CS2 (version 9) and later do not write image resource 1058 in a TIFF file.

Here is a sketch of the content of a TIFF example from various versions of Photoshop:

- Photoshop 6 - big-endian TIFF
 - IFD 0 - 256, 257, 258, 259, 262, 270, 282, 283, 284, 296, 33723 (IPTC), 34377 (PSIR)
 - Tag 34377 PSIR - 1028 (IPTC), 1034, 1035, 1058 (Exif)
 - 1058 - Exif as little-endian TIFF
 - IFD 0 - 270, 271, 272, 274, 282, 283, 296, 306, 531, 34665 (Exif)
 - IFD 1 - 259, 271, 272, 274, 282, 283, 296, 306
 - Exif IFD - 27 typical tags
- Photoshop 7 - big-endian TIFF
 - IFD 0 - 256, 257, 258, 259, 262, 270, 271, 272, 282, 283, 284, 296, 305, 306, 315, 700 (XMP), 33723 (IPTC), 34377 (PSIR), 34665 (Exif)
 - Exif IFD - 25 typical tags
 - Tag 34377 PSIR - 1028 (IPTC), 1034, 1035, 1061
- Photoshop CS2 (version 9) - big-endian TIFF
 - IFD 0 - 256, 257, 258, 259, 262, 270, 271, 272, 282, 283, 284, 296, 305, 306, 315, 700 (XMP), 33432,

33723 (IPTC), 34377 (PSIR), 34665 (Exif)

- Exif IFD - 26 typical tags
- Tag 34377 PSIR - 1028 (IPTC), 1034, 1035, 1061

3.3.5 Metadata storage in Mac OS file resources

Mac OS versions of Photoshop through Photoshop CS (version 8) also wrote some metadata in Mac OS file resources. These resources are not written by Photoshop CS2 (version 9) or later. The resources are shown in [Table 52](#):

Table 52 — Mac OS Photoshop resources from older versions

Resource Name	Value	Description
ANPA	10000	IPTC metadata (this takes priority for reconciliation of multiply-defined values; see 2.4.1, "Reconciliation issues")
pnot	0	Keywords and description

The value of the ANPA 10000 resource is a sequence of IPTC DataSets, as previously described.

The pnot resource was created by Apple for annotation information as part of QuickTime. Its structure is shown in [Table 53](#). Only the KeyW and Desc additional items are of interest for metadata.

Table 53 — Structure of Apple pnot resource

Offset	Length	Description
0	4	Modification timestamp as a 32-bit big-endian Mac OS time
4	2	Version number, 16-bit big-endian integer
6	4	Resource type for preview
10	2	Resource ID for preview, 16-bit big-endian integer
12	2	Number of additional items, 16-bit big-endian integer
14	-	Sequence of additional items

Each additional item has the structure shown in [Table 54](#). Only the associated resource for the KeyW and Desc items is of interest for metadata.

Table 54 — Structure of additional items

Offset	Length	Description
0	4	Modification timestamp as a 32-bit big-endian Mac OS time
4	4	OSType defining the usage of this item
8	4	Resource type for the associated data
12	2	Resource ID for the associated data, 16-bit big-endian integer
14	2	Region code for this item, 16-bit big-endian integer
16	4	Reserved

The items whose usage is KeyW or Desc are of interest for metadata. The KeyW item should have an associated STR# resource that contains the keywords. A STR# resource contains a 16-bit big-endian count of

strings followed by a sequence of Pascal strings. The Desc item should have an associated TEXT resource that contains the description. A TEXT resource simply contains text.